

# stigwize

## Stigwize 5G 4x4 MiMo Outdoor Antenna



**Product** Stigwize 5G 4x4 MiMo Outdoor Antenna

**SKU** STI-5G-MIMO-SMA-5M

**EAN** 8785285640869

**Capestone articlenumber** STI10006



# Stigwize 5G MiMo Outdoor Antenna

Upgrade the performance of your 5G network with the Stigwize 5G 4x4 MiMo antenna, the best 5G antenna and a powerhouse in mobile data connectivity designed to meet the demands of enterprises looking for reliable and efficient network solutions.

In a world where connectivity is critical, the Stigwize 4x4 5G MIMO antenna is the ideal choice for professionals who want to stay at the forefront of 5G network technology. Improve your connectivity, enhance productivity and experience the future of networking with Stigwize.

## Features

- Type: OMNI MIMO Directional
- 3G: Frequency & Gain: 700-960MHz 2dBi
- 4G LTE: Frequency & Gain: 1700-2700MHz 5dBi
- 5G NR: Frequency & Gain: 3300-3800MHz 5dBi
- Cables: 4x 5 meters CLF200 Low Loss
- Connector: SMA
- Voltage standing wave ratio:  $\leq 3.2$
- Power: 100 W
- Dimensions HxWxD (cm): High 44 x Wide 7.4 x Depth 7.4 cm

## Key features

- **4x4 MiMo Technology:** With four transmit and four receive antennas, this antenna maximizes signal quality, minimizes interference and ensures optimal network performance.
- **High-Gain Design:** With its high-gain antenna design, this device significantly expands the coverage area of your 5G network. Thus, blind spots are reduced and overall connectivity is improved.
- **Easy installation:** The Stigwize 5G MiMo antenna comes with mounting hardware for quick installation. It also allows for rapid integration into your existing network infrastructure.
- **Weatherproof construction:** this 5G outdoor antenna is made of sturdy materials and built to withstand harsh environmental conditions, ensuring long-term reliability.

## Applications

- Retail: Stores can deploy 5G antennas to ensure their POS systems stay connected even during network outages. Uninterrupted sales transactions are possible as a result. Major retailers such as [CEWE](#) are also deploying 5G routers and 5G antennas to connect their IoT devices and printers to a reliable 5G mobile data connection.
- 5G for outdoor areas: the Stigwize 5G 4x4 MiMo outdoor antenna is ideal for providing high-speed 5G Internet access in rural areas where traditional broadband options may be limited. Namely, the Stigwize 5G MiMo antenna can pick up 5G signals from nearby transmission towers and deliver reliable Internet connectivity to homes and businesses in remote locations.
- Construction sites: Construction sites often lack reliable network connectivity. The Stigwize 5G MiMo outdoor antenna can be installed on construction sites to ensure project managers, engineers and workers have consistent access to communication and project management tools. This has improved efficiency and safety.
- Surveillance systems: Security and surveillance systems in remote or outdoor locations can benefit from the Stigwize 5G MiMo outdoor antenna. It provides a stable Internet connection for IP cameras and surveillance equipment. Real-time video streaming and remote access to surveillance feeds is thus possible.



## About Stigwize

Stigwize is an antenna brand for 4G, 5G, WiFi and GPS antennas for the business market. Stigwize antennas can be used in all kinds of vertical sectors including IoT, Enterprise, Retail, Construction, Mobility, Security and Maritime.

As the European distributor of Stigwize, Capestone supplies the complete antenna portfolio. This portfolio includes 4G and 5G antennas for indoors and outdoors, vandal-resistant puck antennas and screw antennas for mounting on 5G routers.

When stigmatizing profits, in addition to favorable pricing, there are also various other benefits including a 24-month warranty and a direct SWAP policy. Capestone's engineers can also put together custom antennas for projects, so that you always have the most suitable solution, as you have come to expect from Capestone.

Specification STI-5G-MIMO-SMA-5M	
Model No.	<b>STI-5G-2MIMO-SMA-5M</b>
Frequency	700-960MHz /1700-2700MHz /3300-3800MHz
Gain (dBi)	700-960MHz 2dBi/1700-2700MHz 5dBi/3300-3800MHz 5dBi
Type	OMNI
Polarization	Vertical
V.S.W.R.	$\leq 3.5$
Temperature	-30°C ~ +70°C
Antenna Connector	SMA MALE x4
Antenna Cable	CLF200 Length=5M x4
Dimensions	L440×W74×H74 mm
Mounting	U-bolts
Wind load	120Km/h

700-960MHz 2dBi/1700-2700 5dBi/3300-3800MHz 5dBi OMNI MIMO ANTENNA x4+CLF200(5M) x4+SMA MALE x4

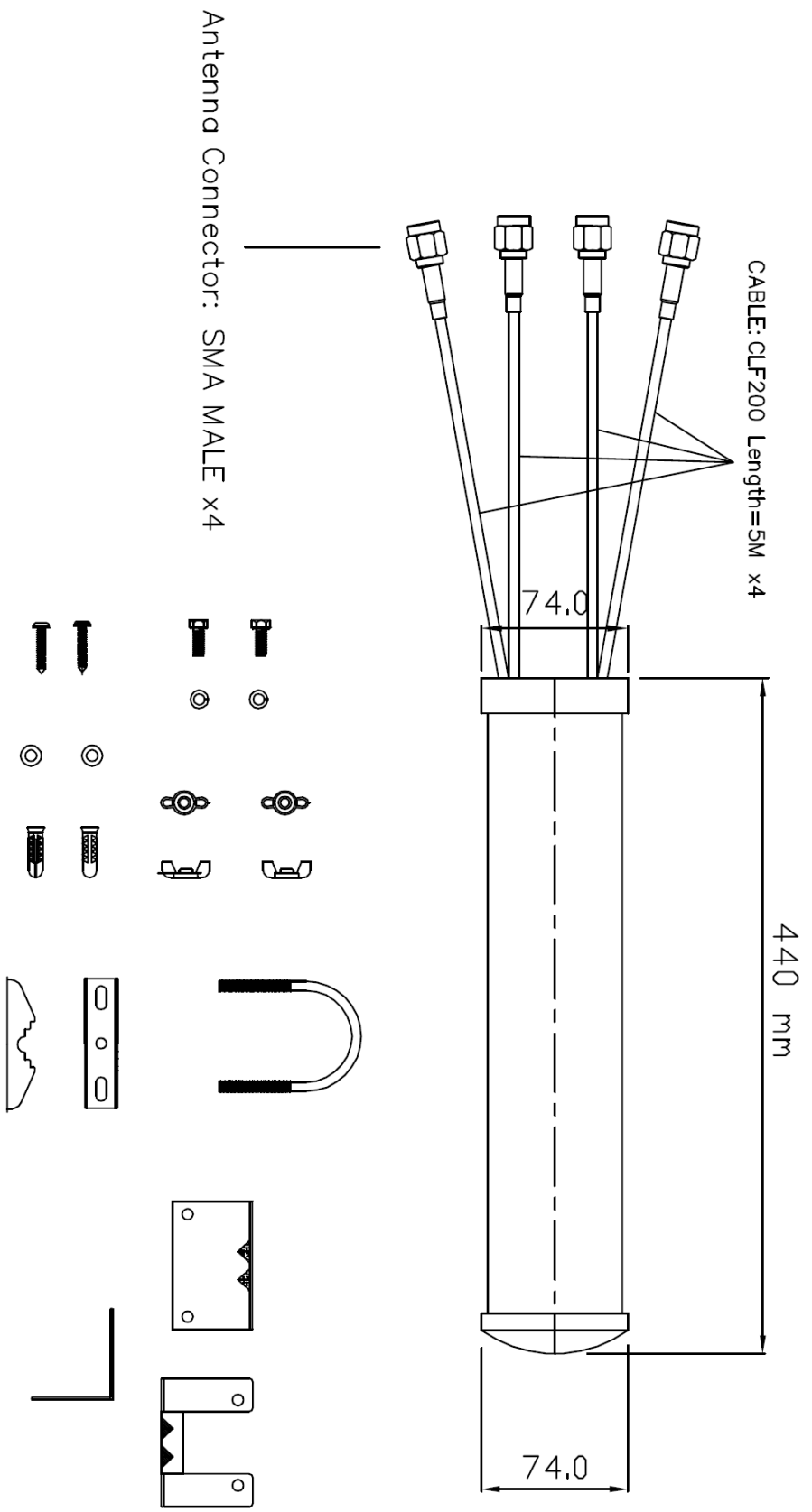

1	FREQUENCY RANGE : 700-960MHz/1700-2700/3300-3800MHz	7	LENGTH : L440xW74xH74 mm
2	GAIN : 700-960MHz 2dBi/1700-2700MHz 5dBi/3300-3800MHz 5dBi	8	Antenna Cable : CLF200 x4
3	TYPE : OMNI	9	Antenna Connector : SMA MALE x4
4	POWER HANDLING : 100W	10	
5	POLARIZATION : LINEAR VERTICAL	11	
6	VSWR : <=3.5	12	

# Antenna 1

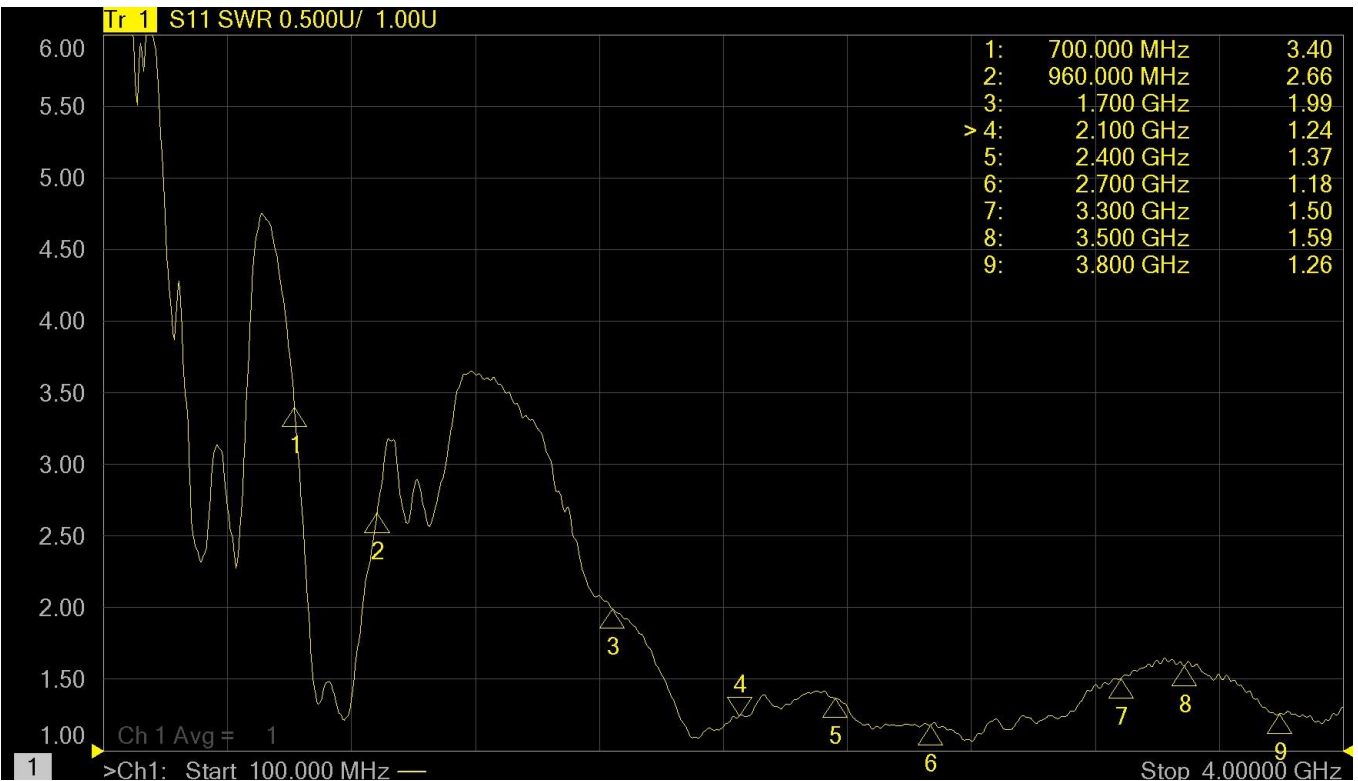
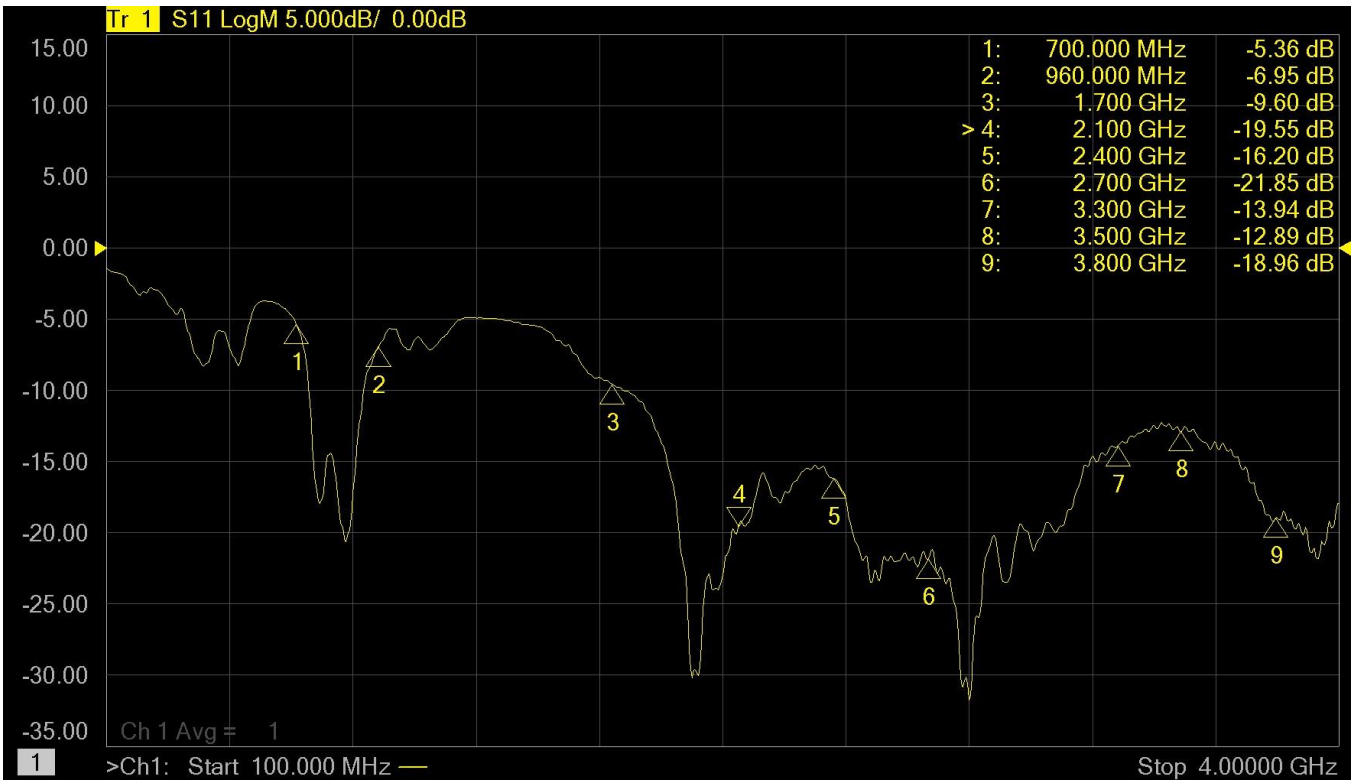

# Radiation pattern

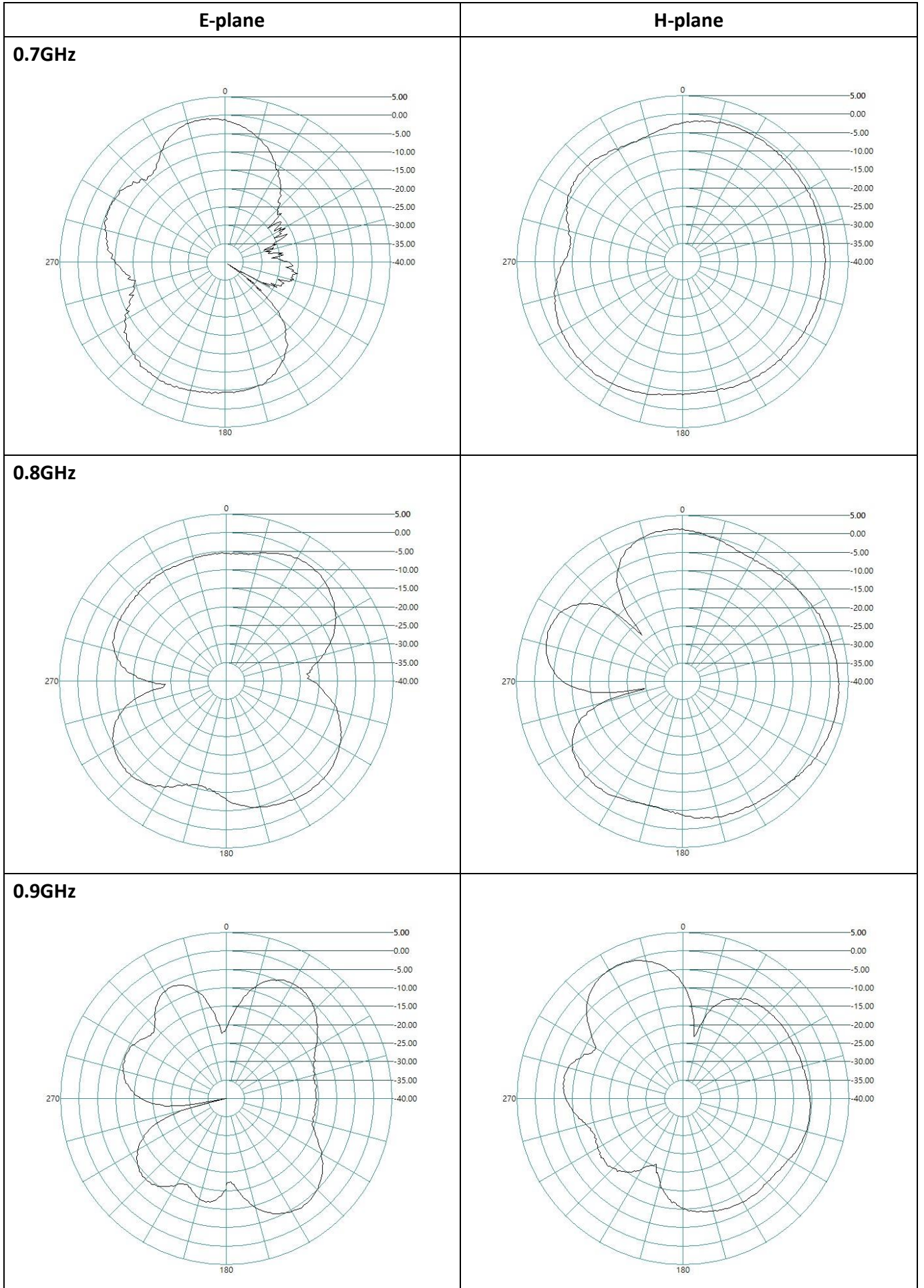

### 1.7GHz

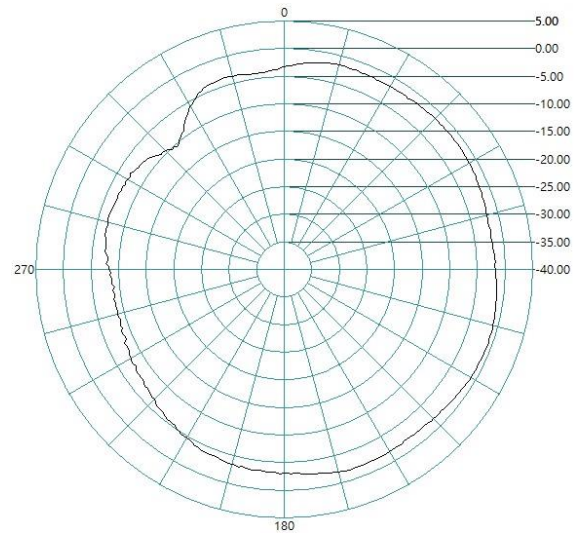
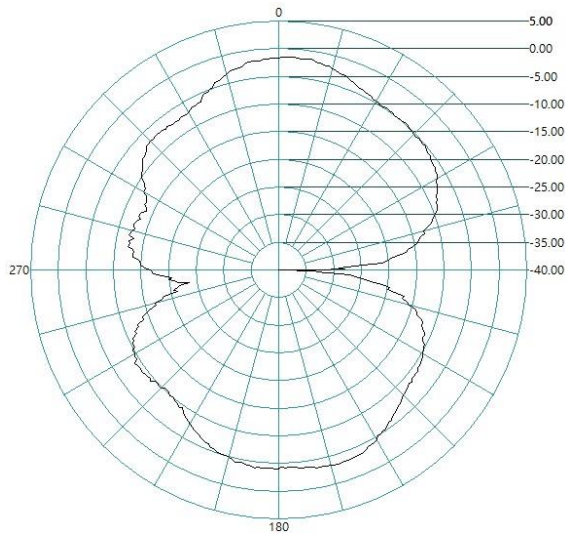

### 1.9GHz

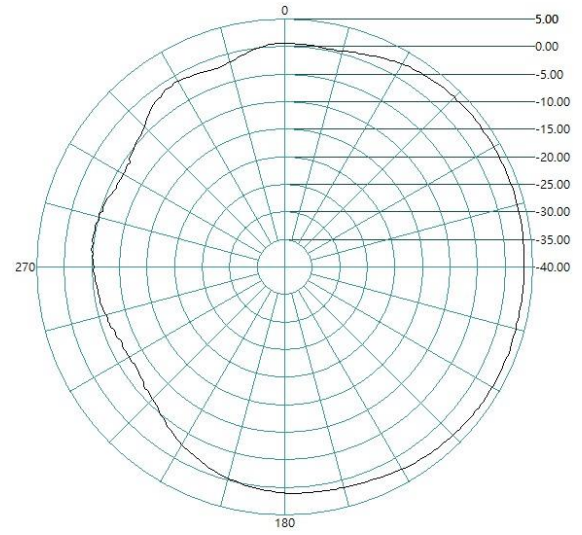
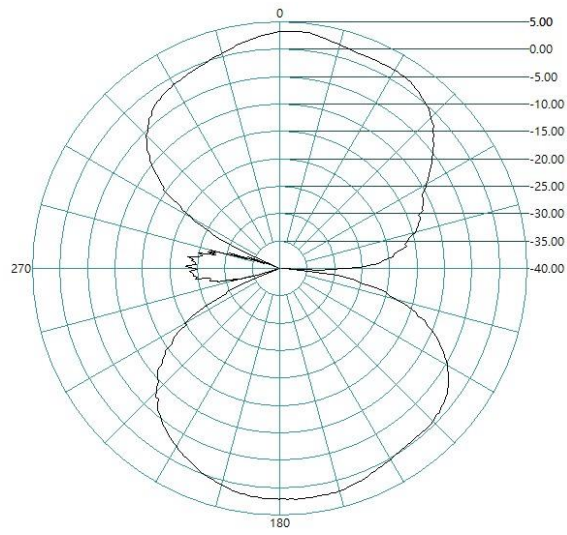

### 2.1GHz

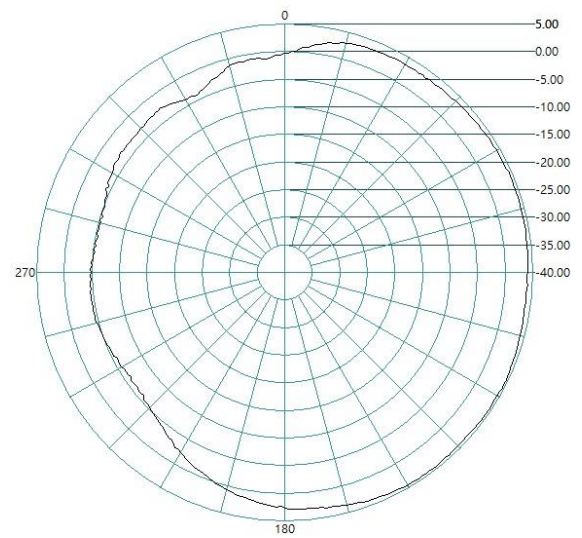
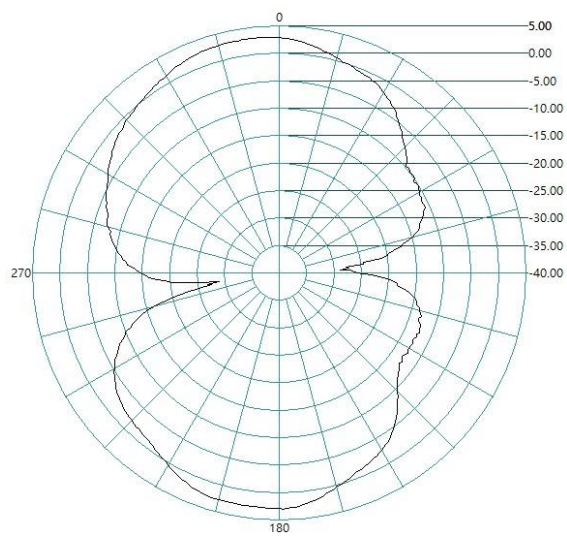



### 2.4GHz

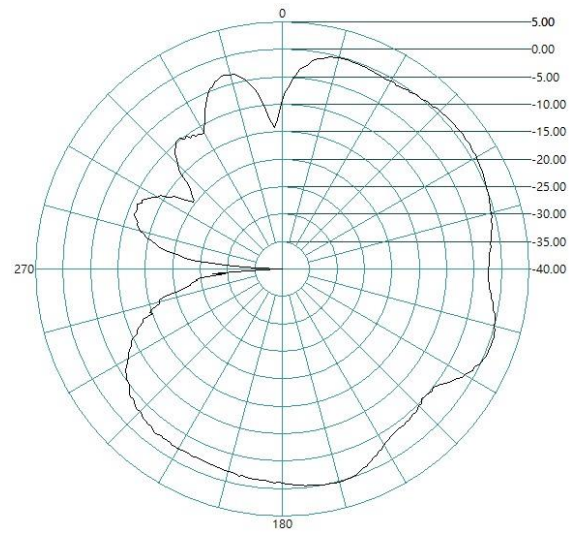
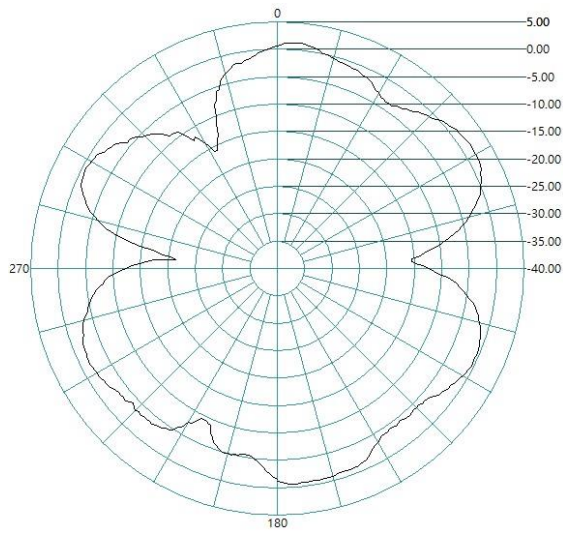

### 2.7GHz

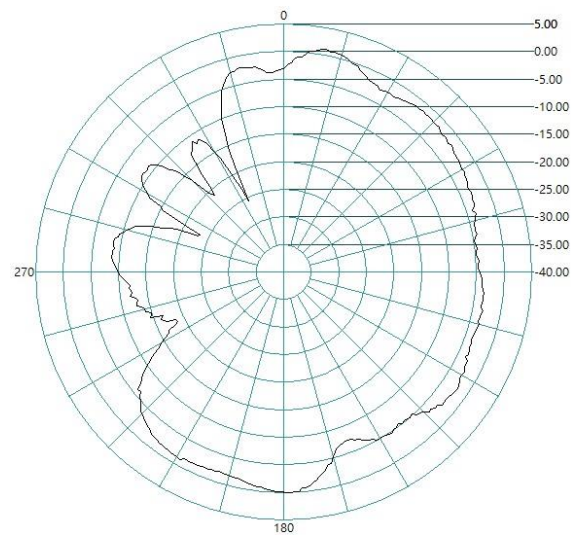
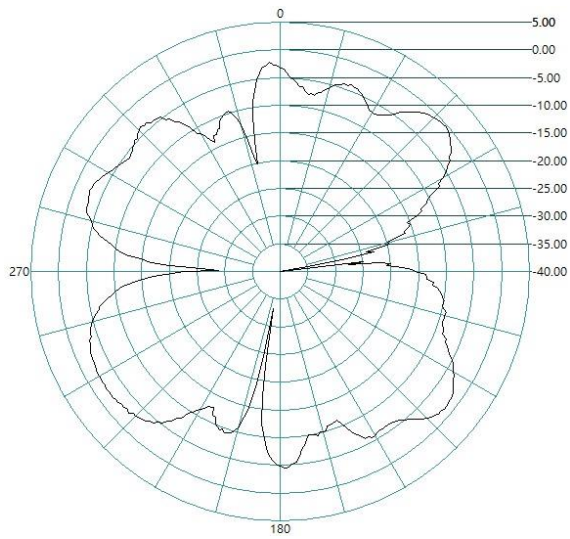

### 3.3GHz

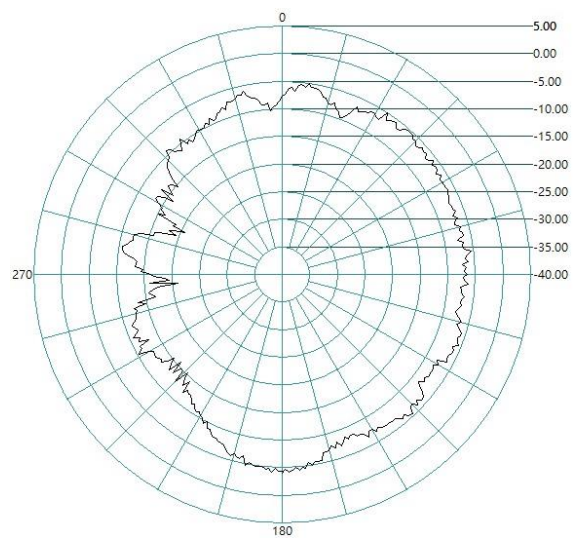
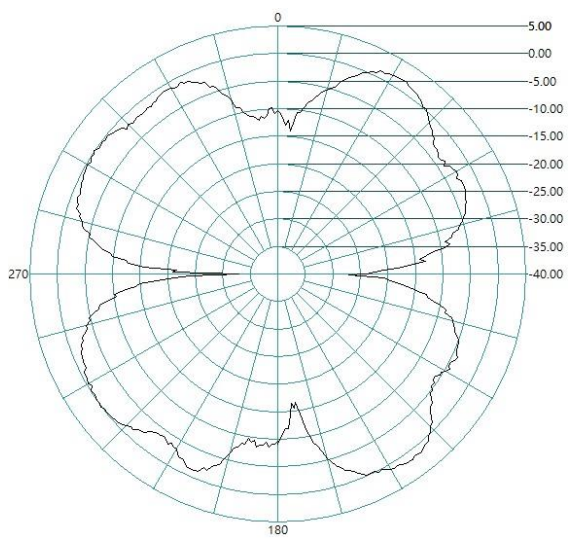

### 3.5GHz

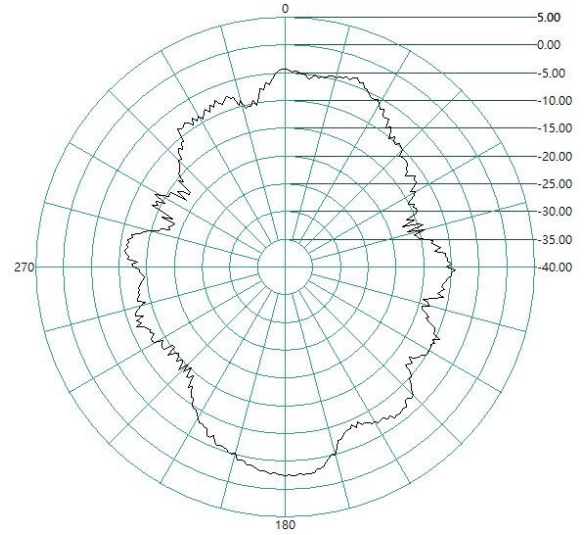
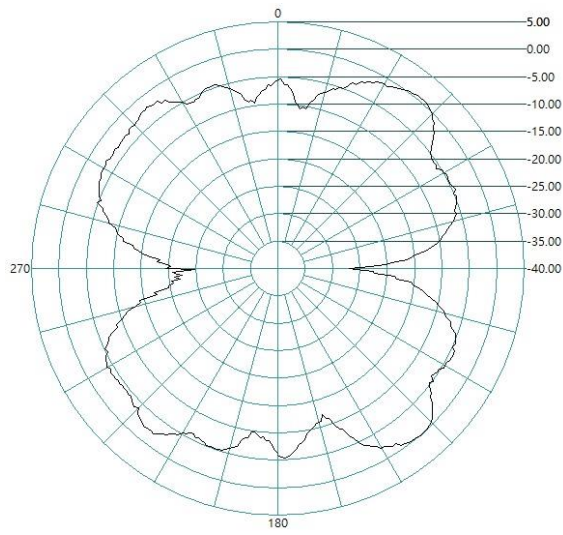

### 3.8GHz

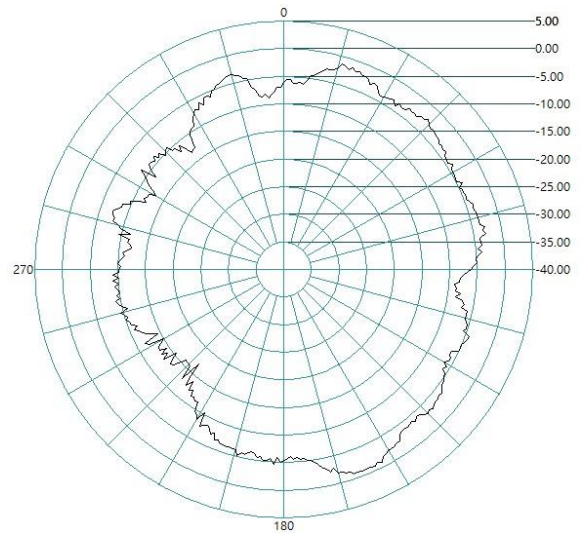
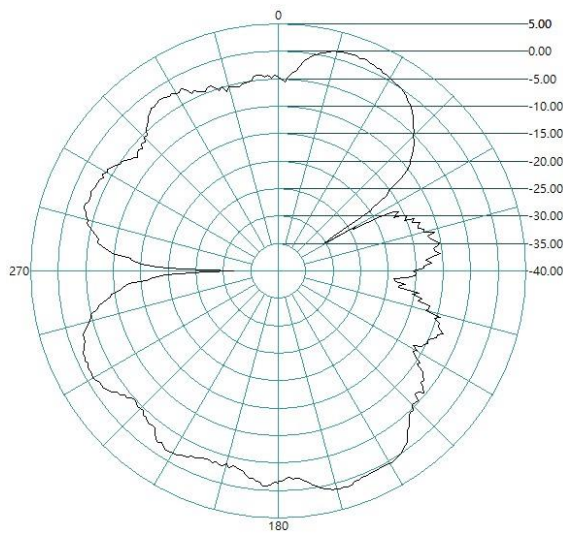

# Antenna 2

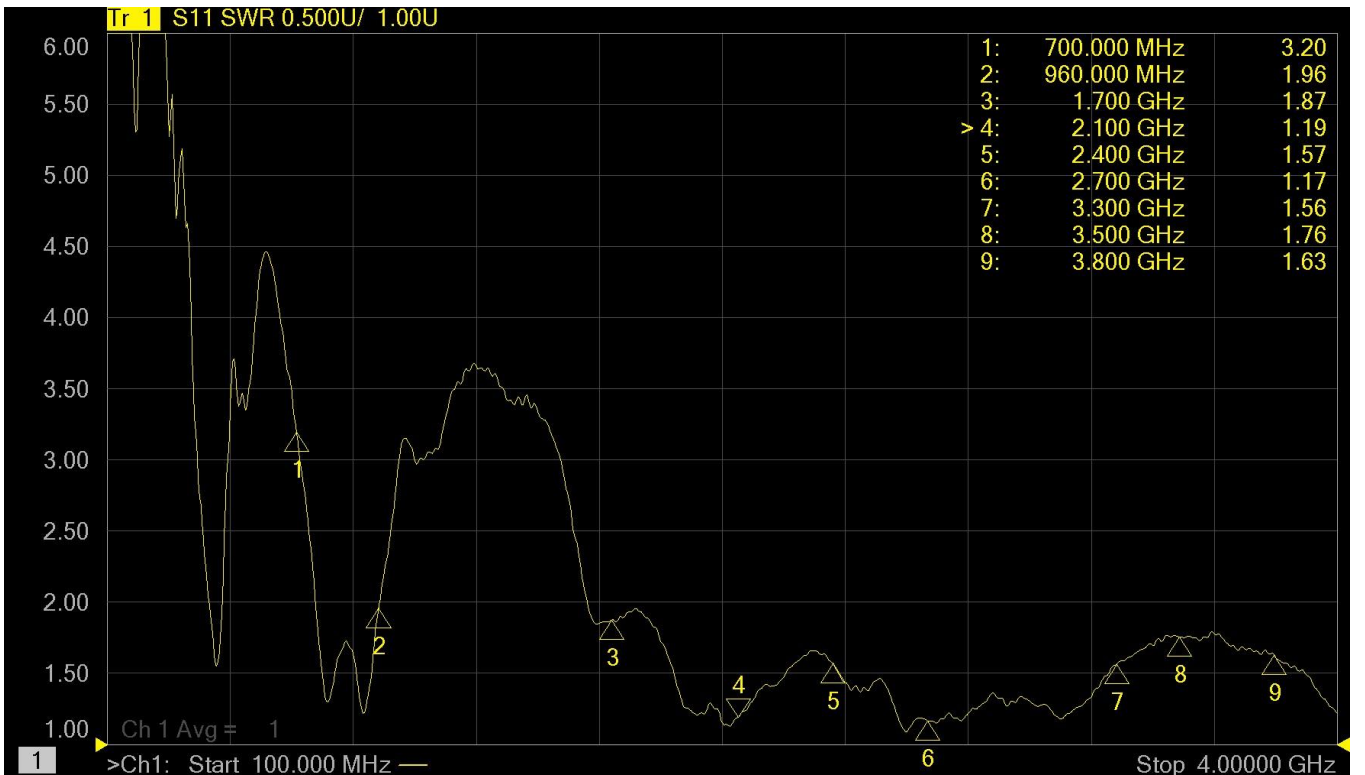
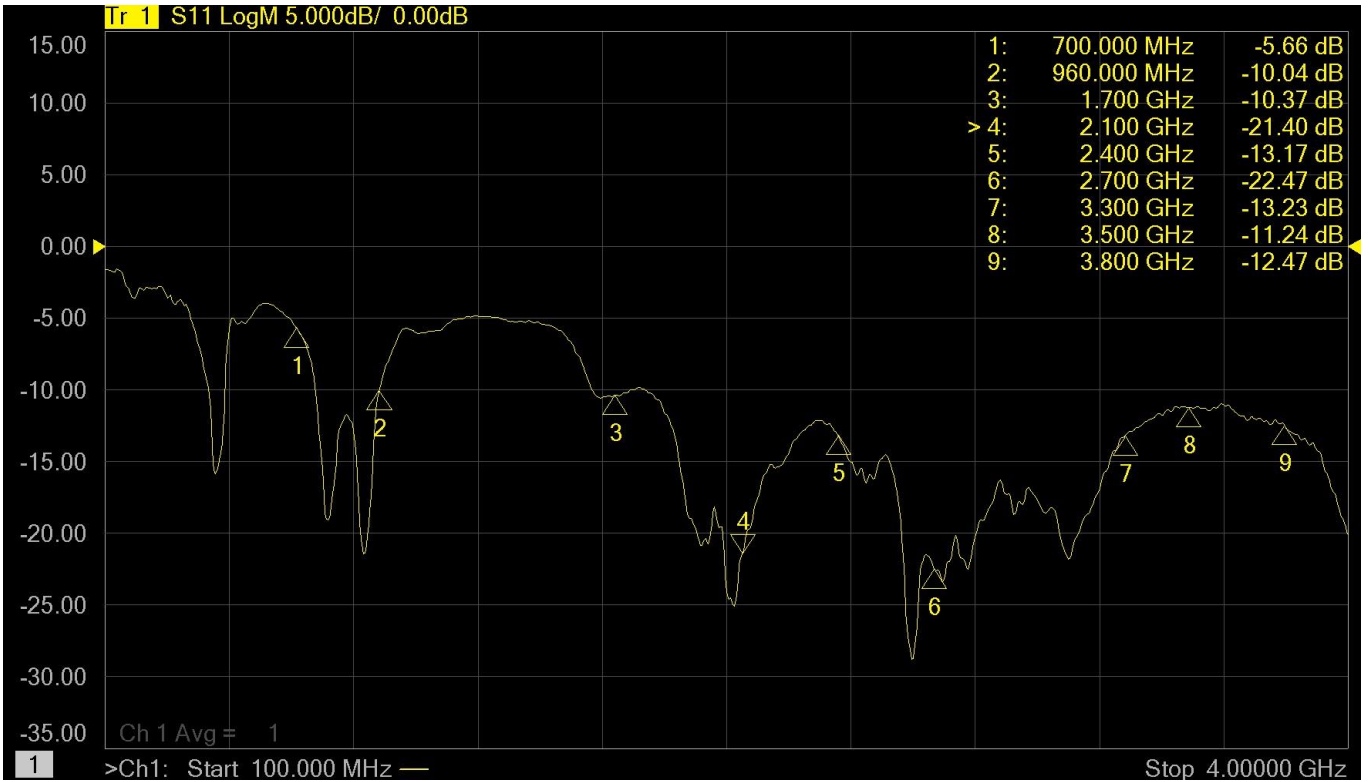

# Radiation pattern

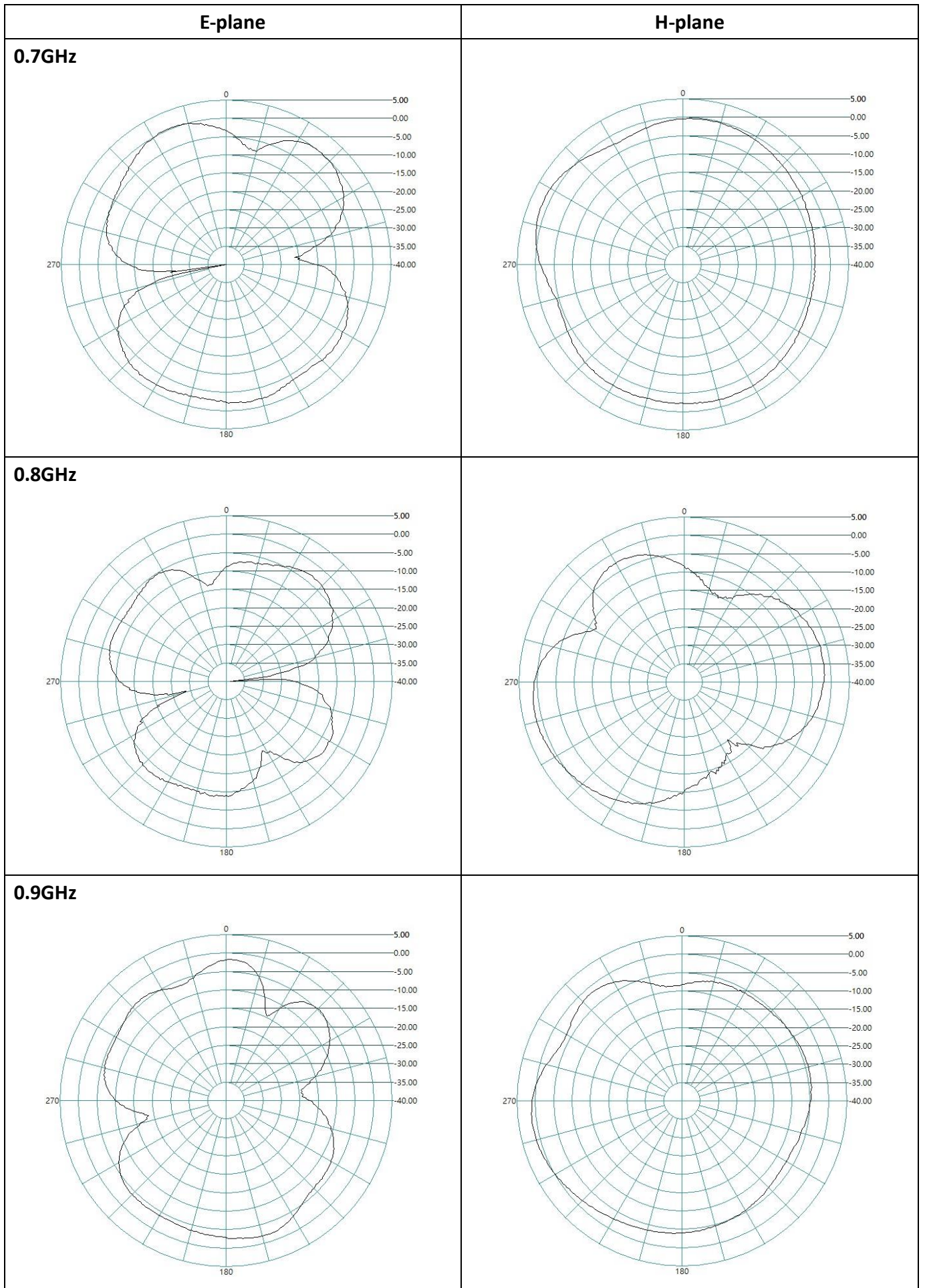

**1.7GHz**

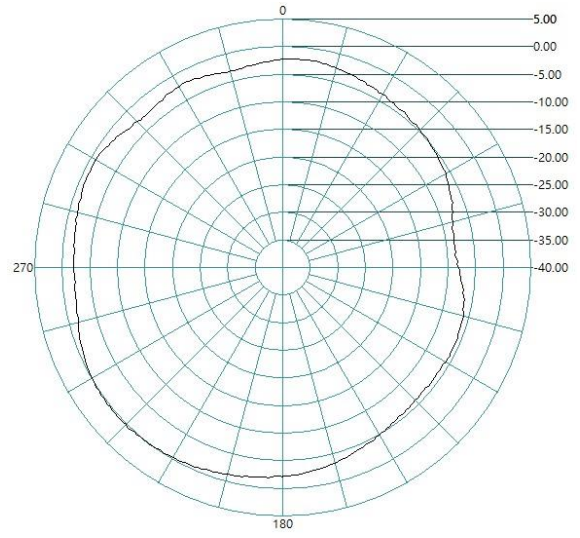
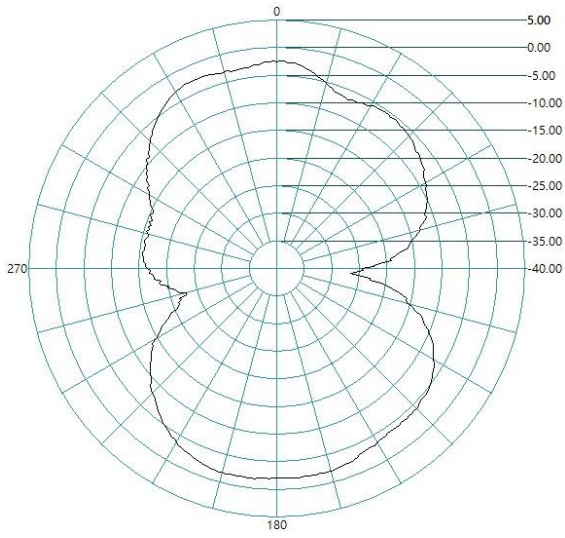

**1.9GHz**

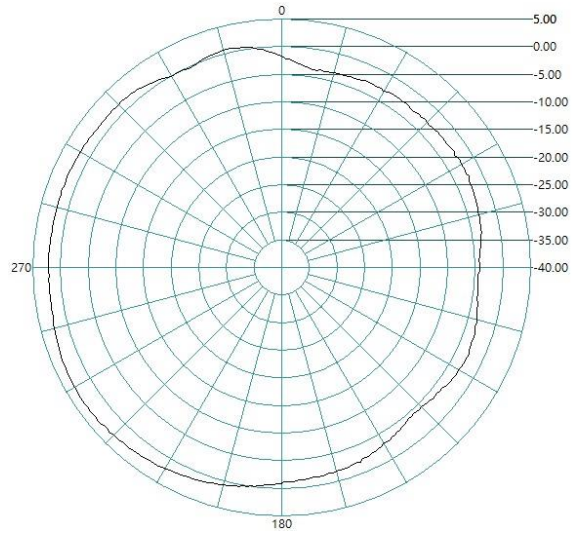
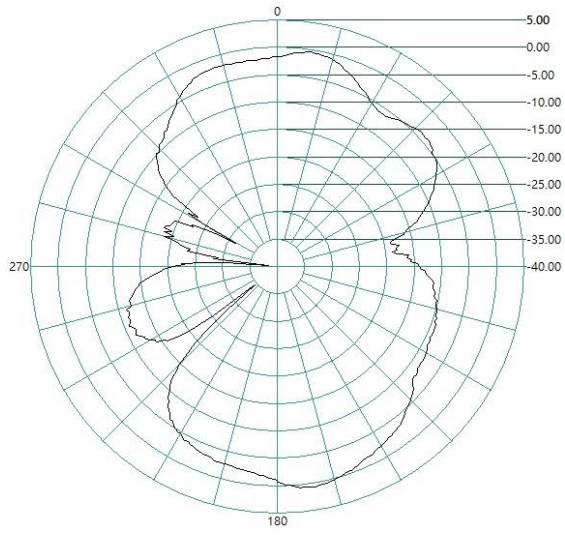

**2.1GHz**

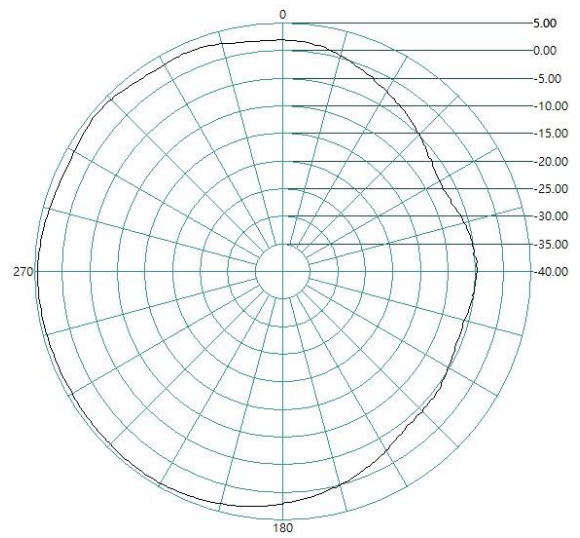
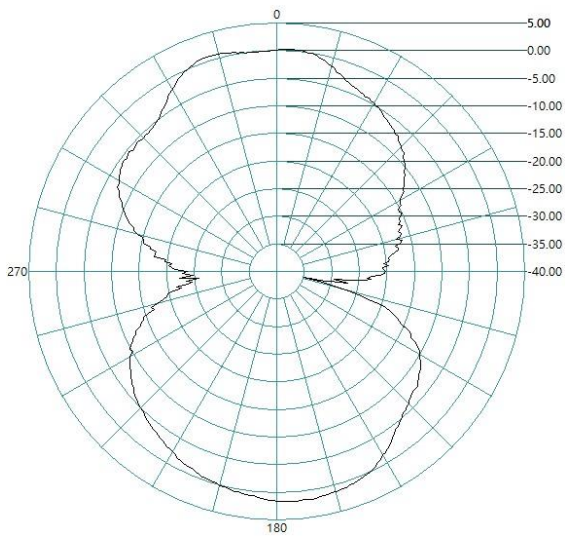

### 2.4GHz

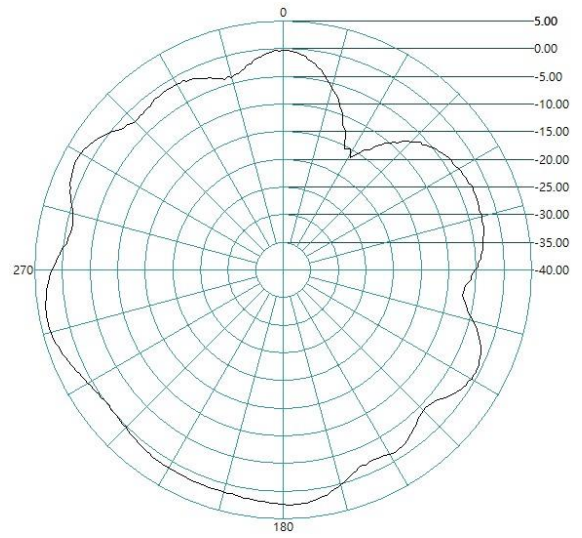
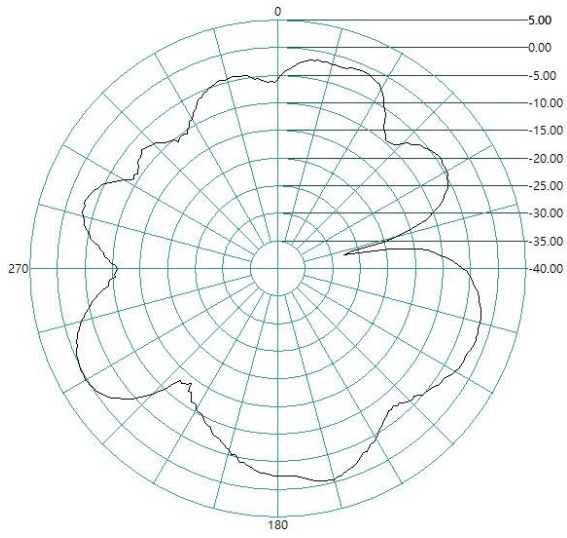

### 2.7GHz

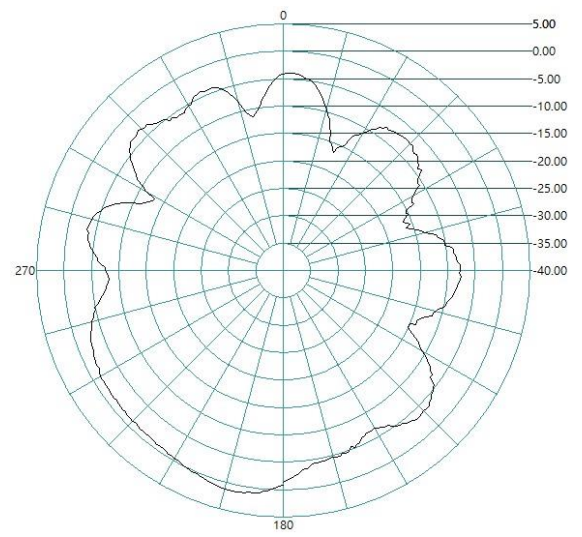
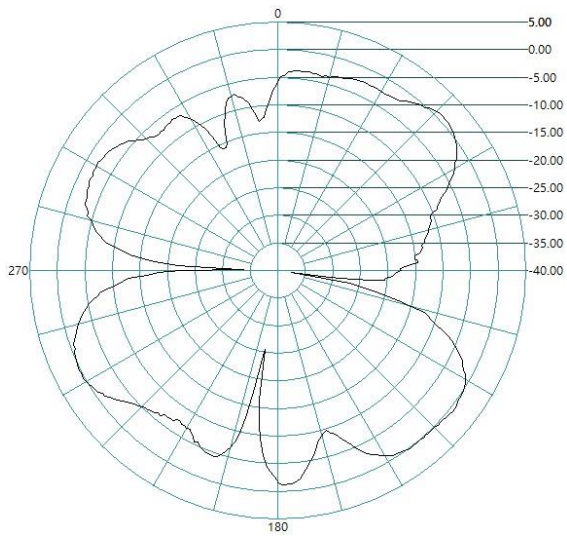

### 3.3GHz

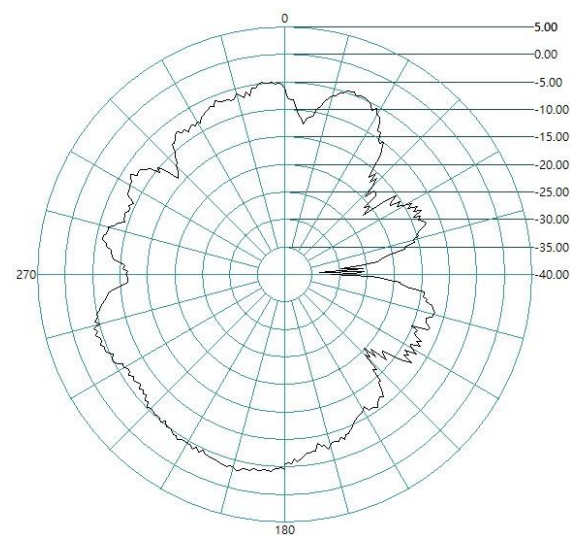
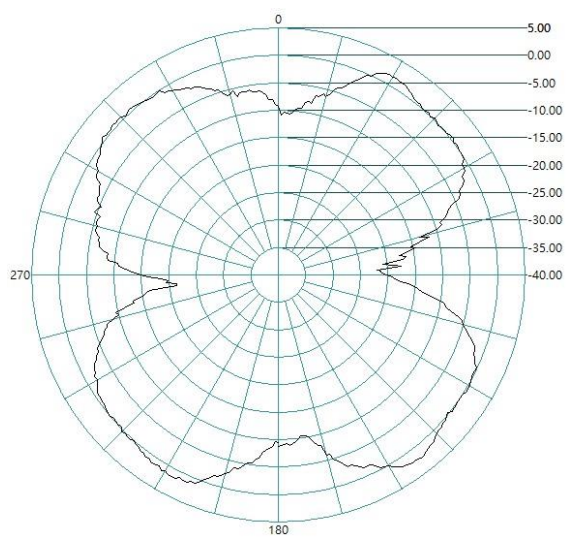

### 3.5GHz

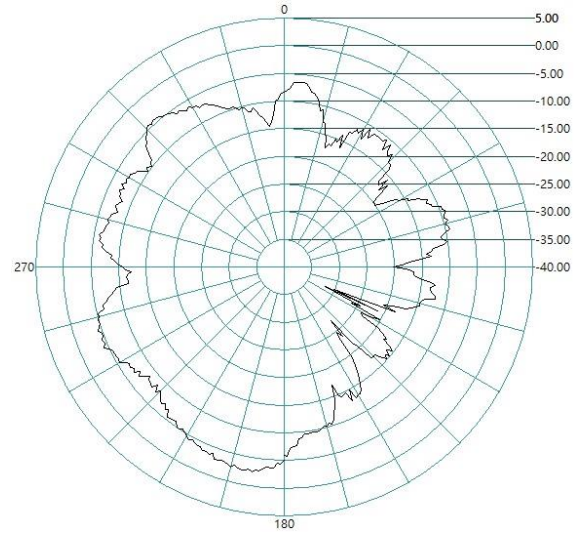
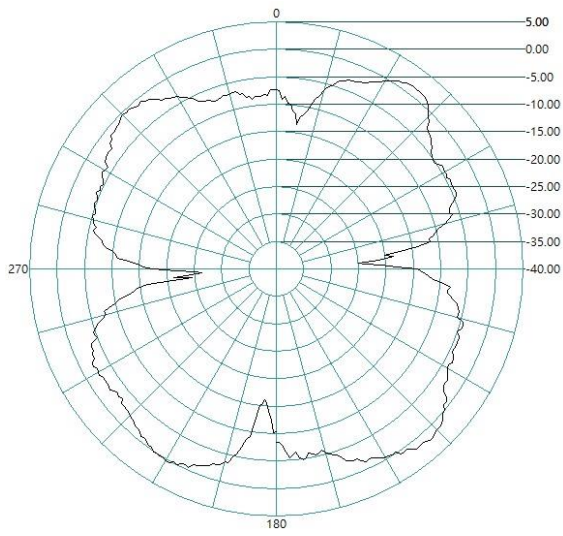

### 3.8GHz

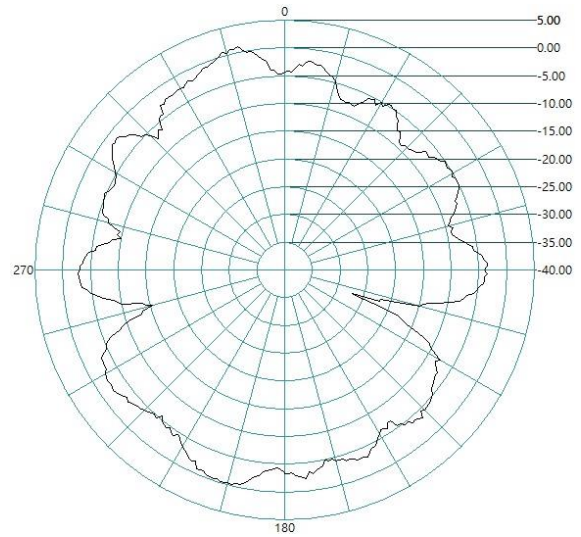
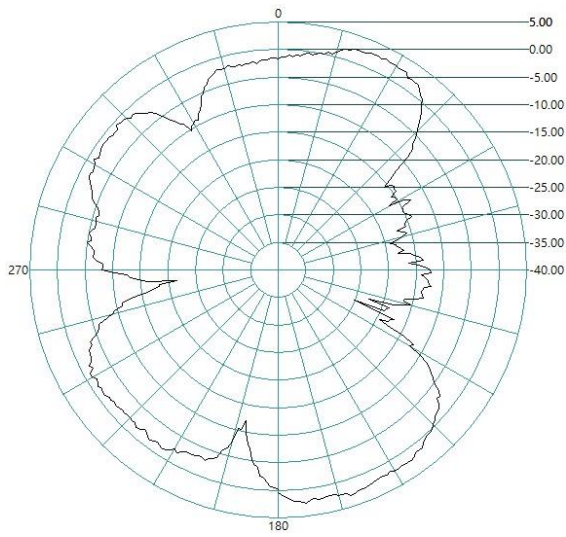

# Antenna 3

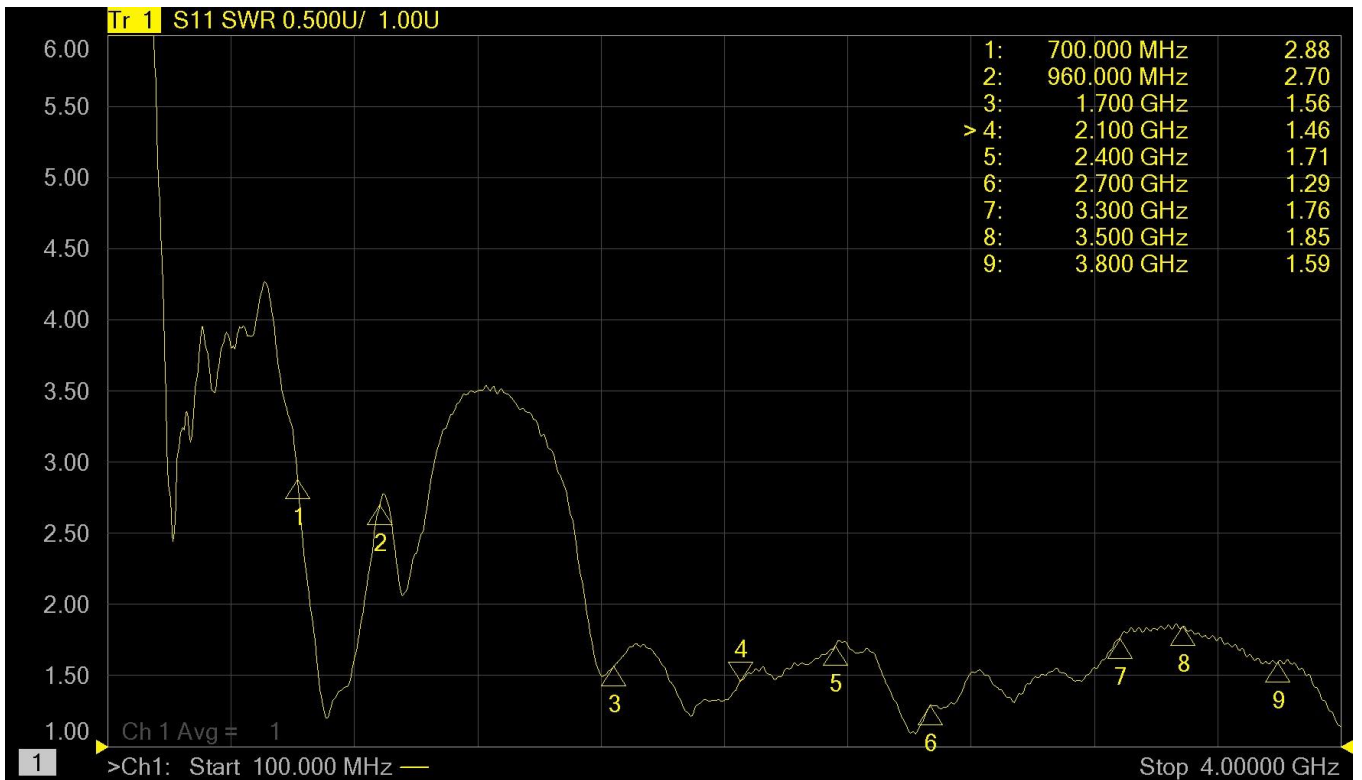
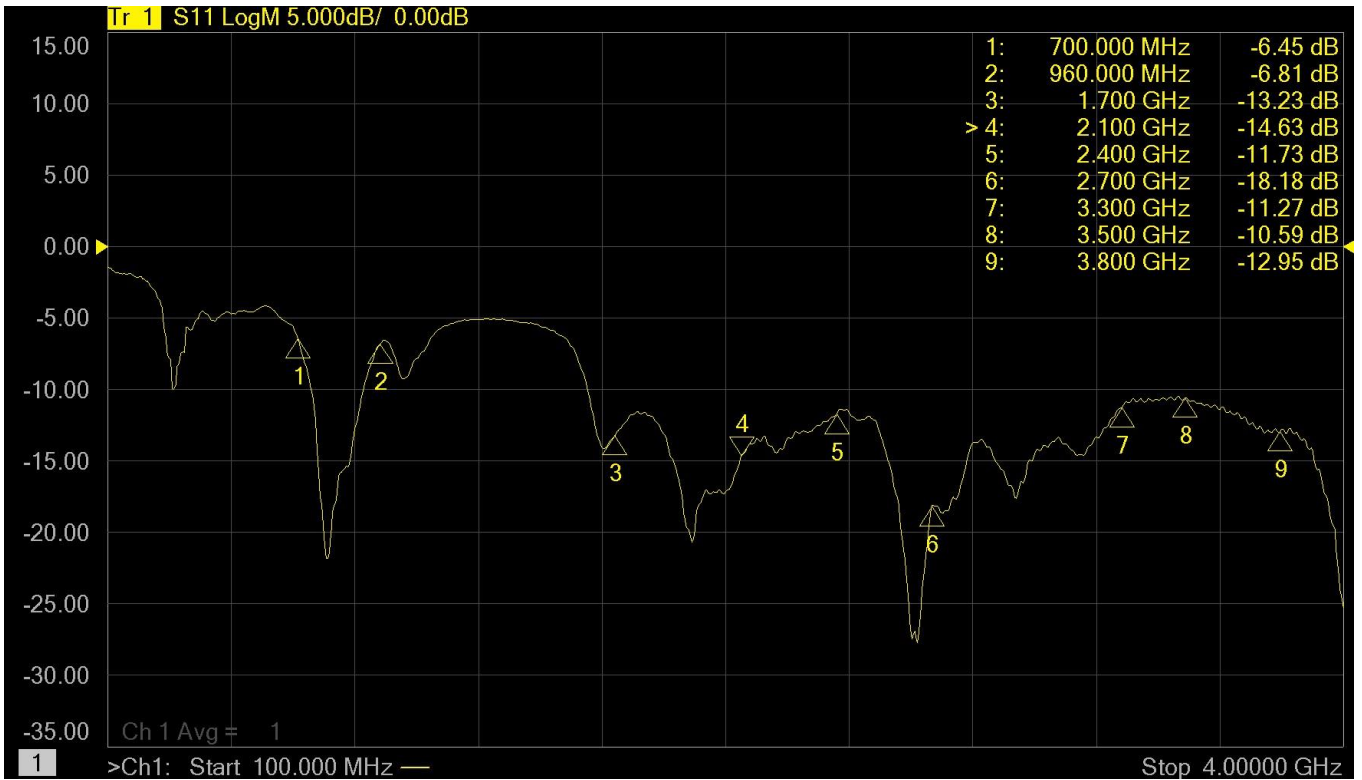



# Radiation pattern

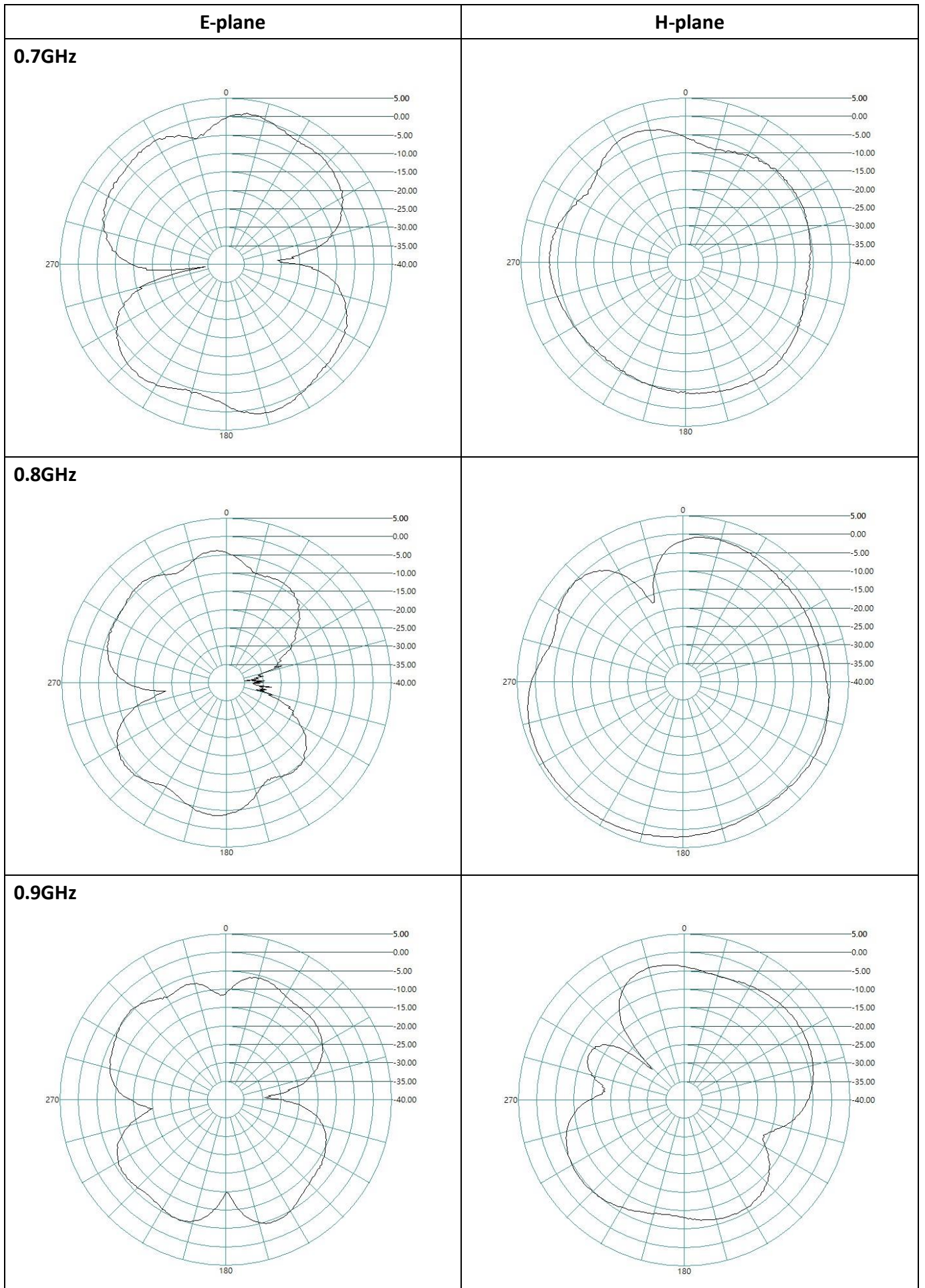

### 1.7GHz

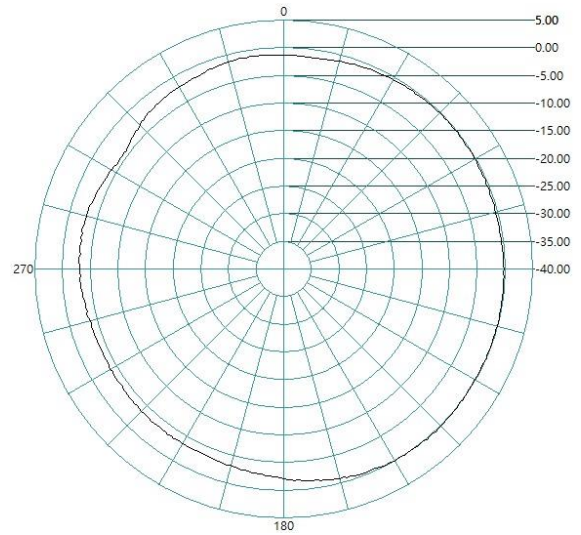
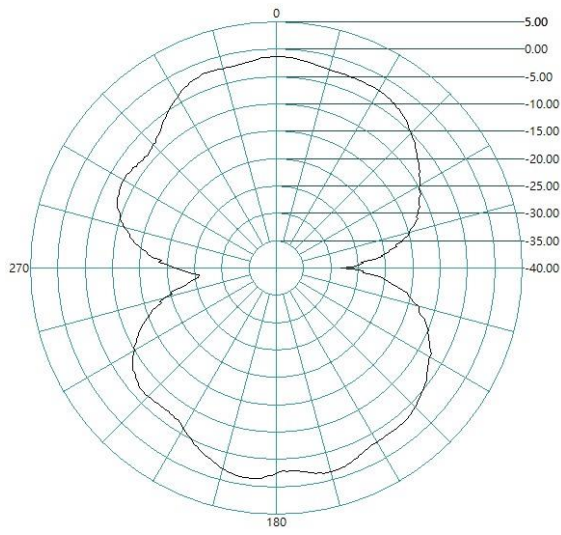

### 1.9GHz

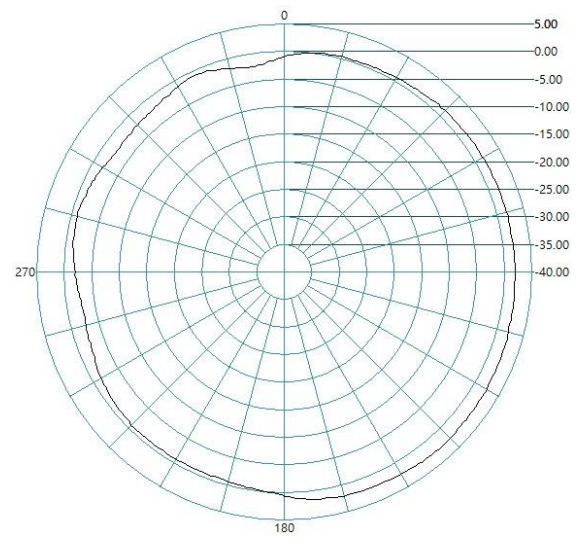
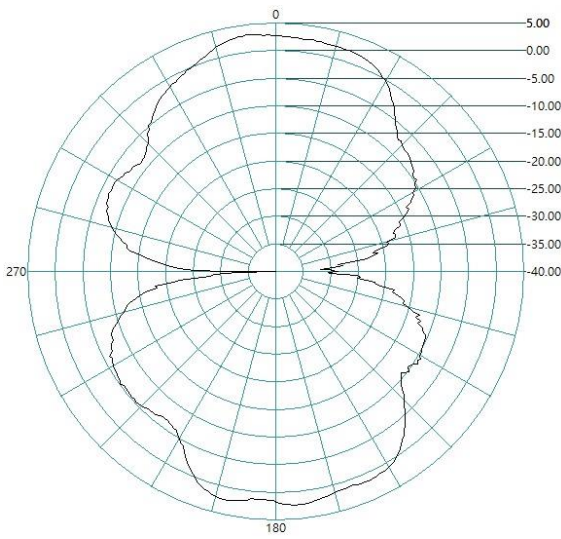

### 2.1GHz

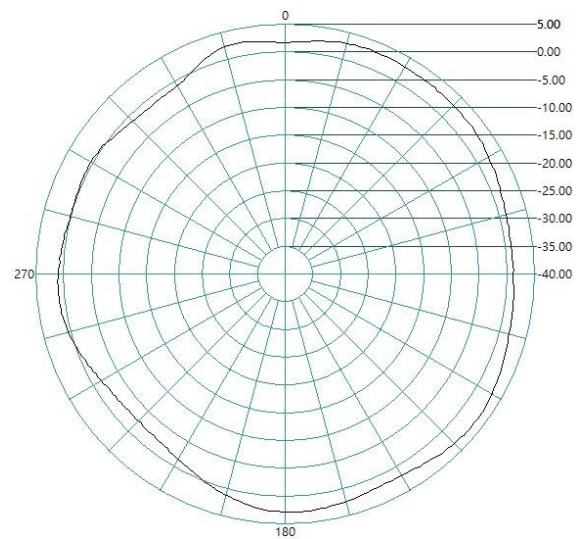
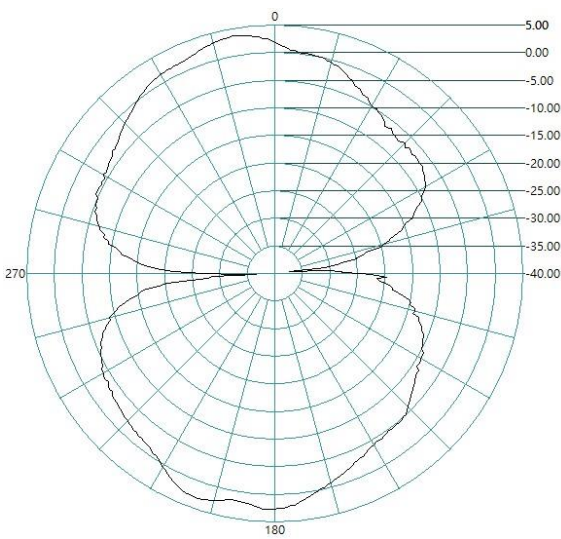

### 2.4GHz

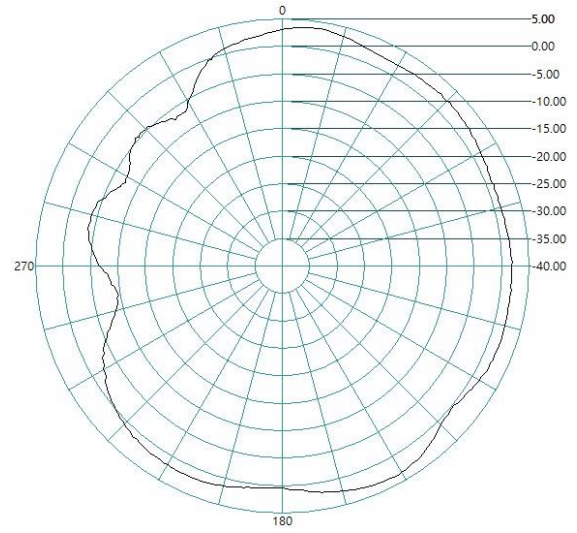
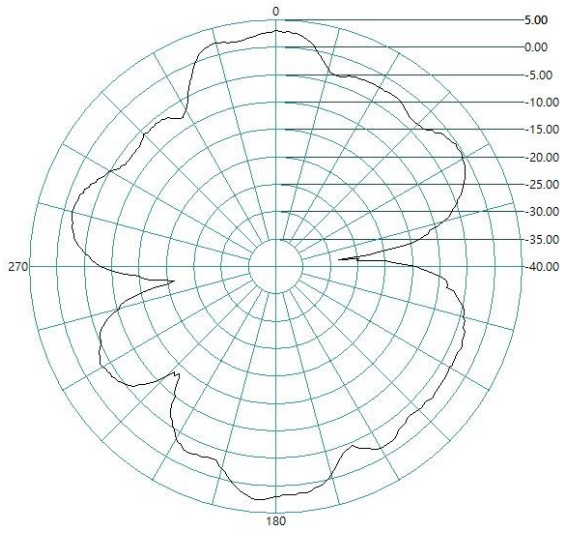

### 2.7GHz

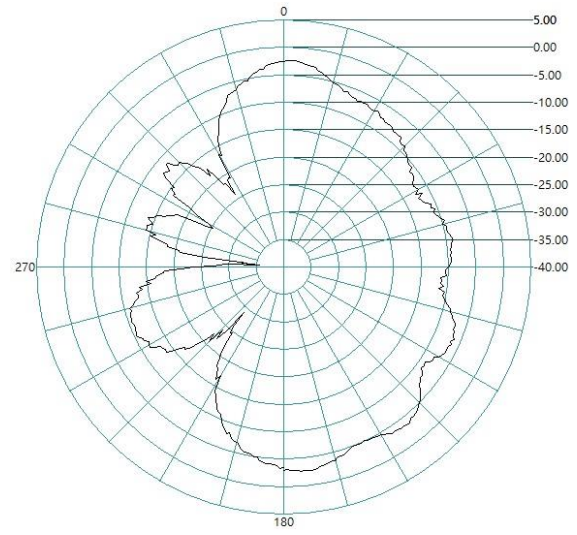
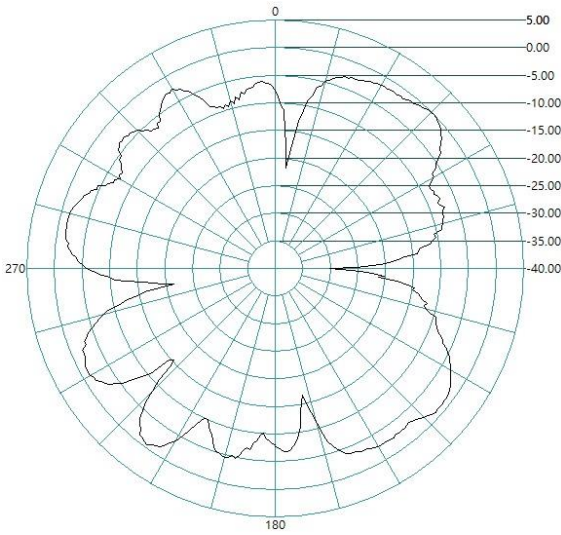

### 3.3GHz

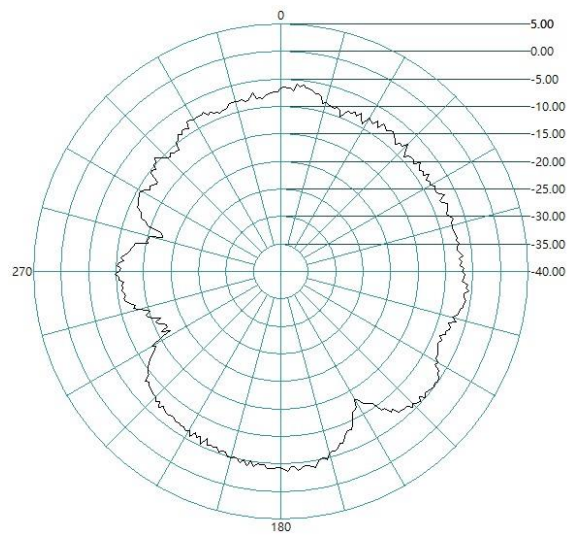
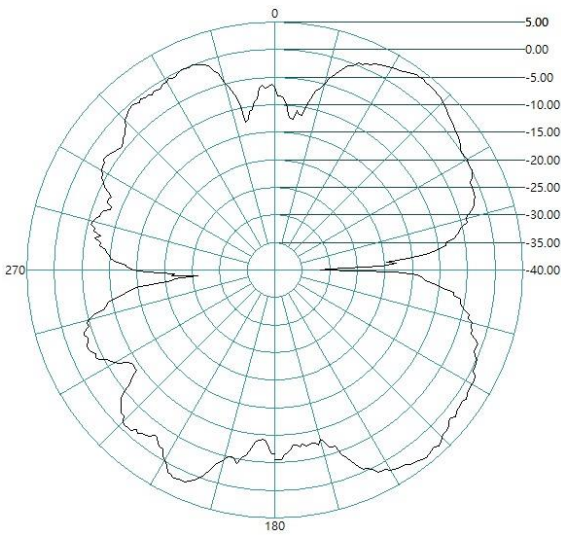

### 3.5GHz

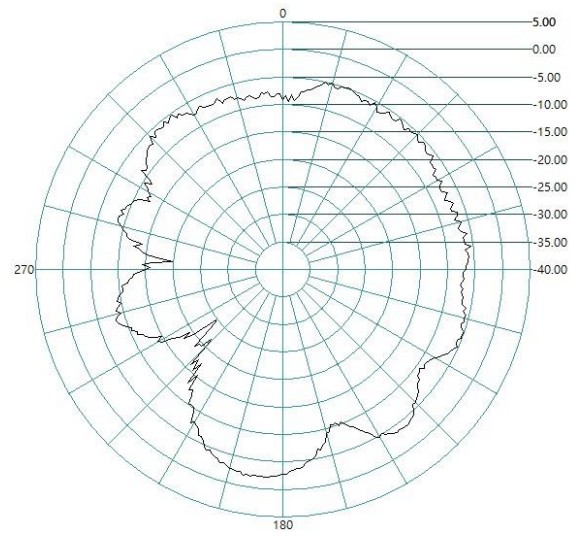
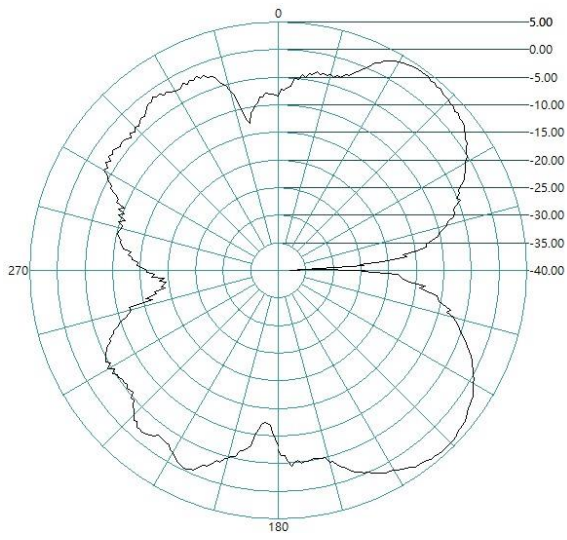

### 3.8GHz

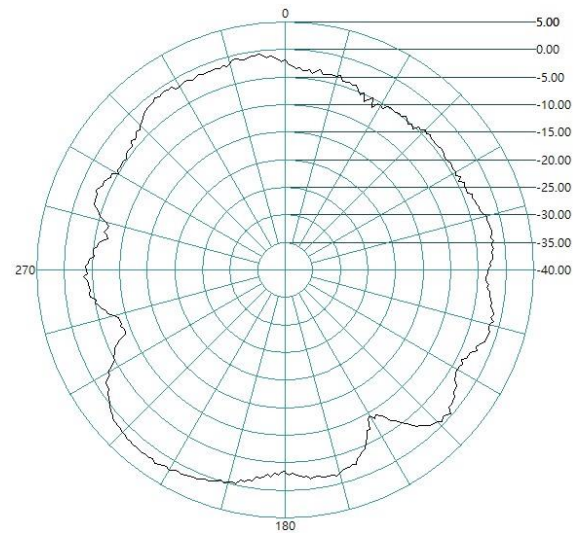
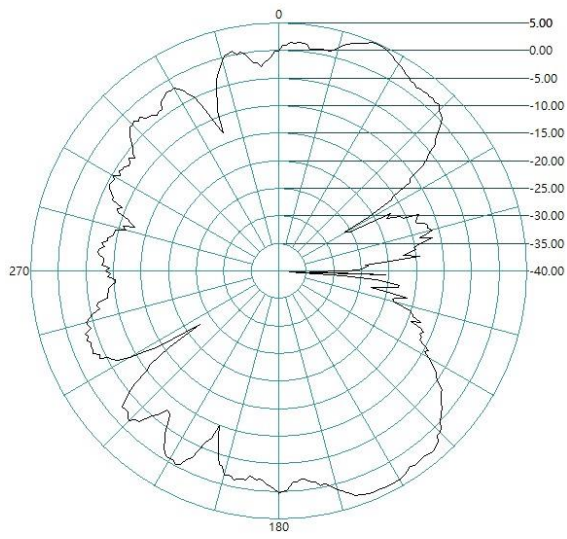

# Antenna 4

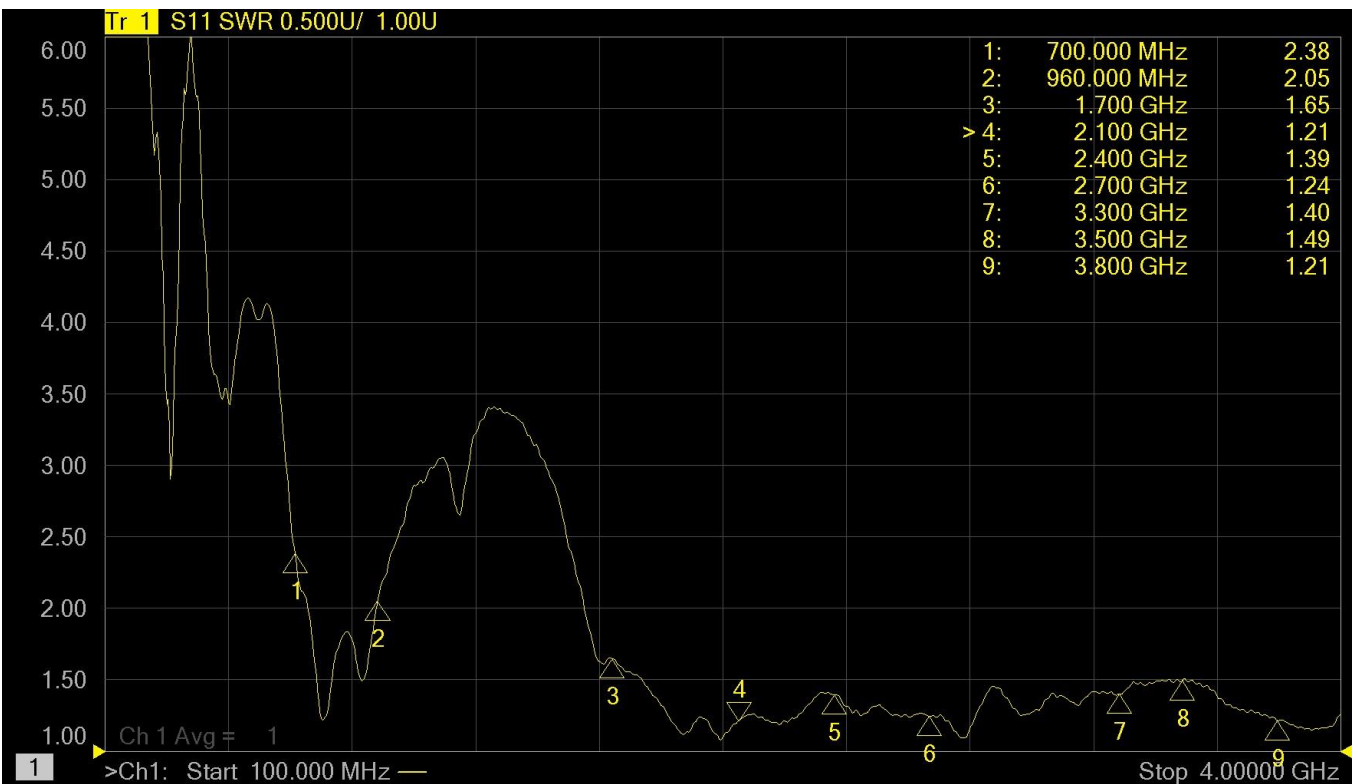
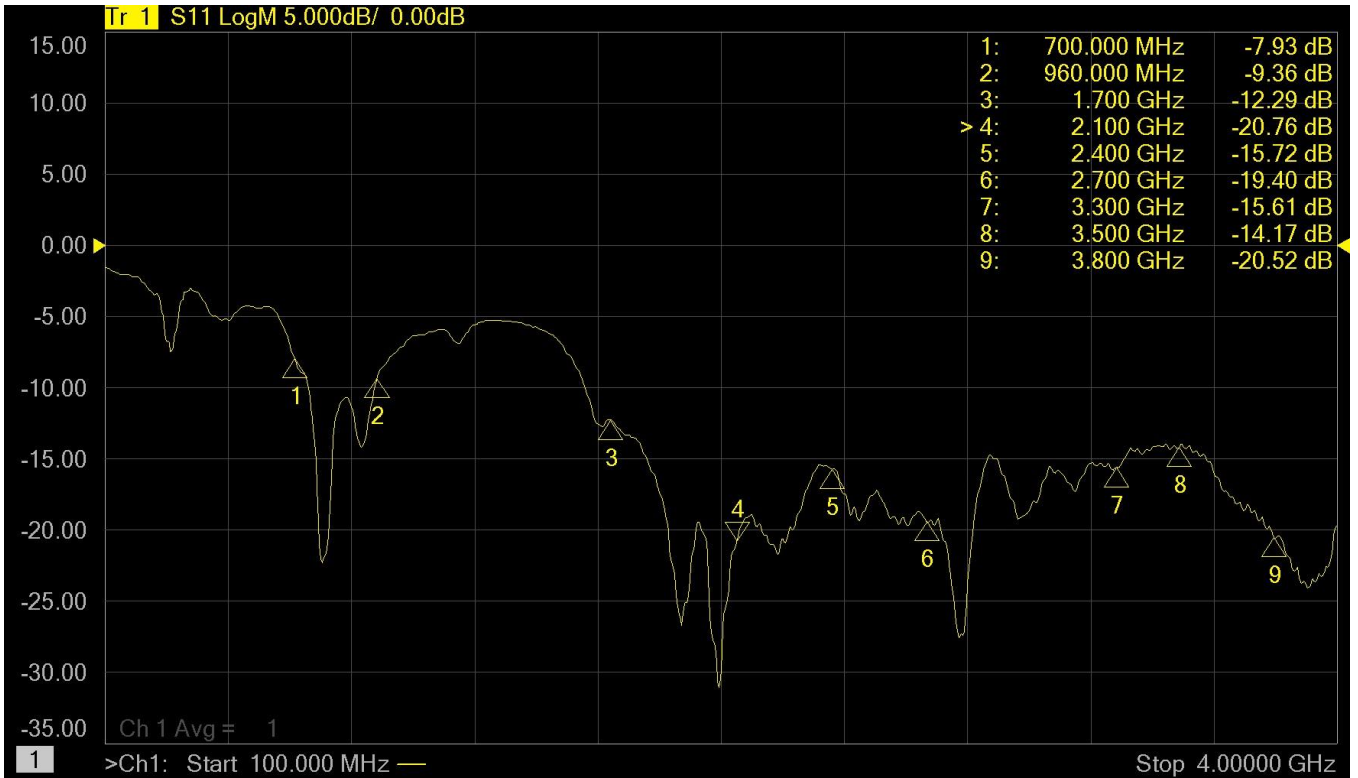

# Radiation pattern

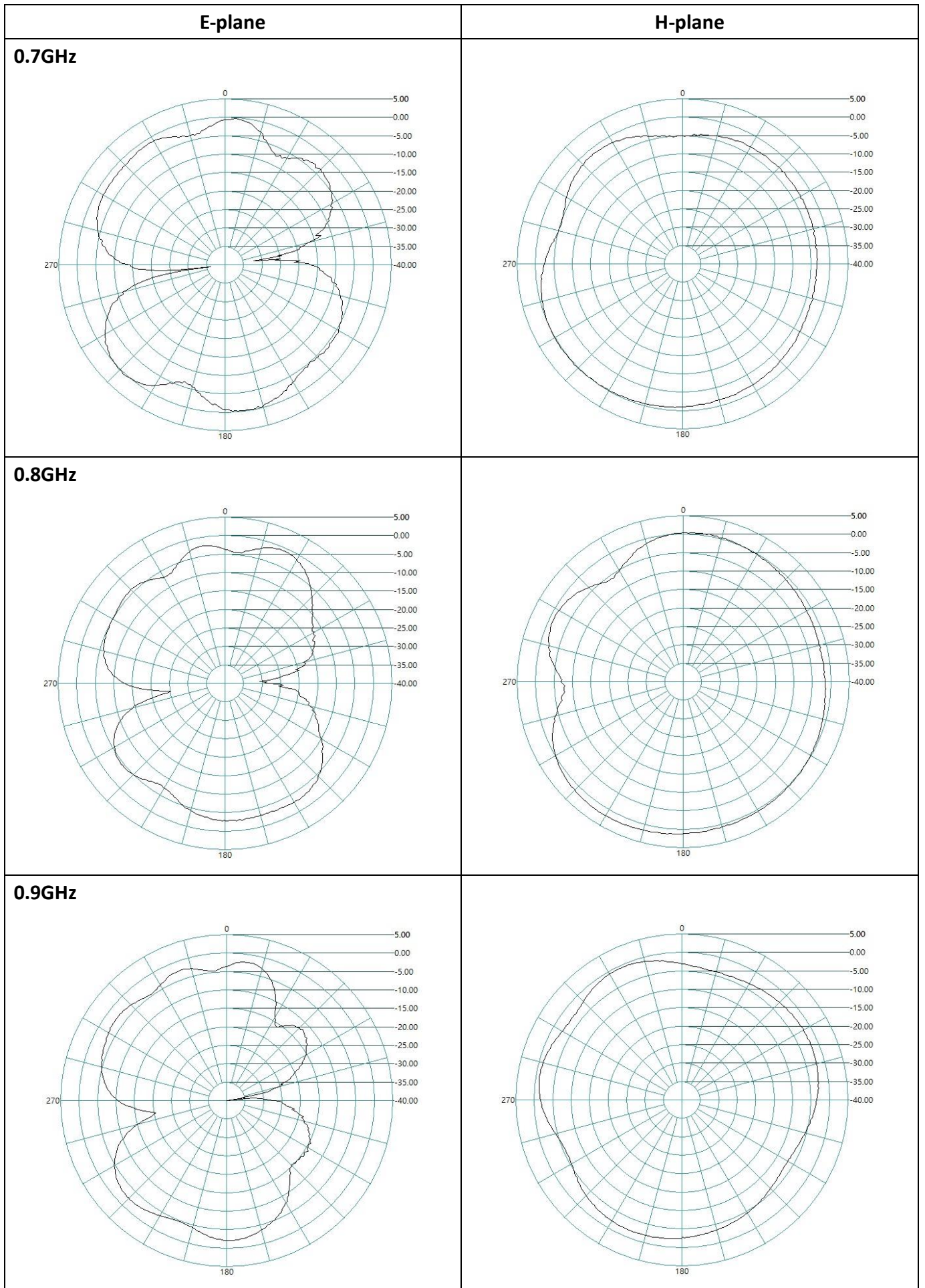

### 1.7GHz

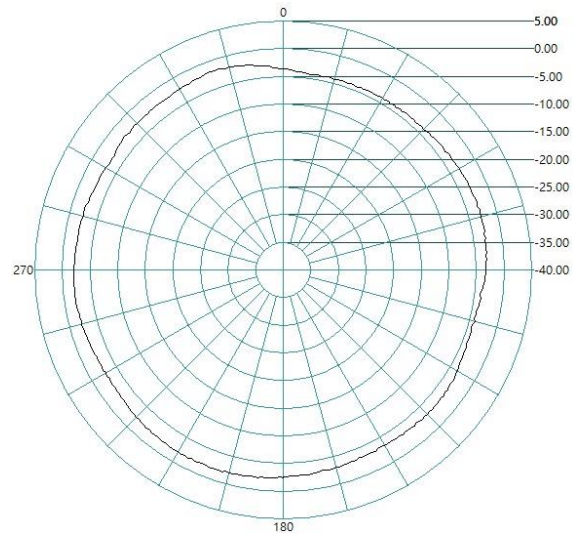
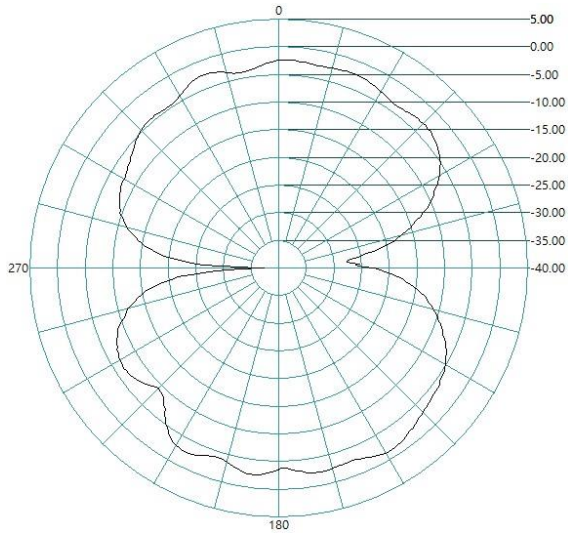

### 1.9GHz

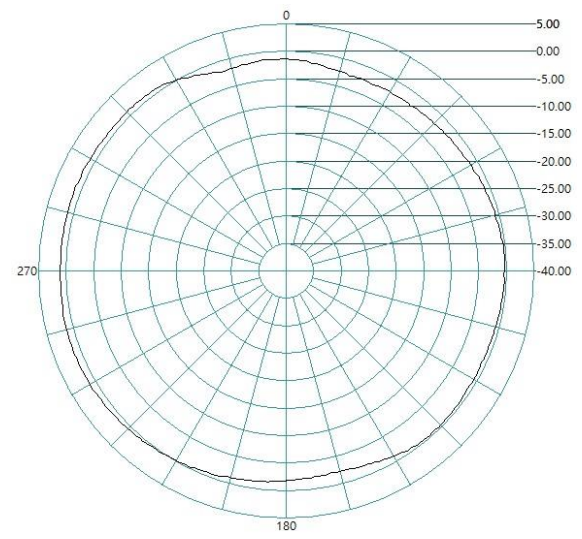
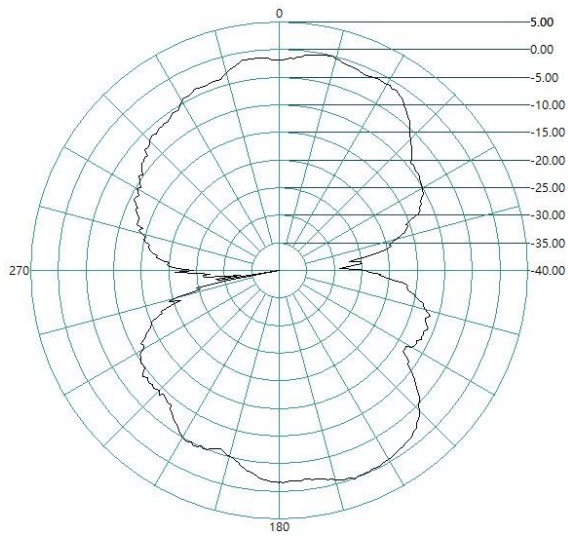

### 2.1GHz

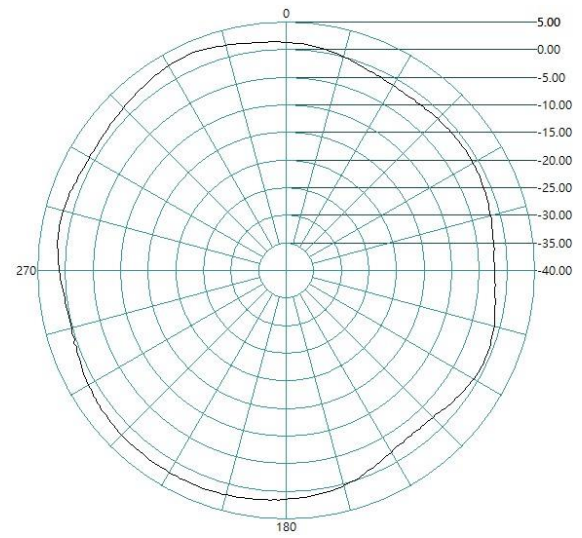
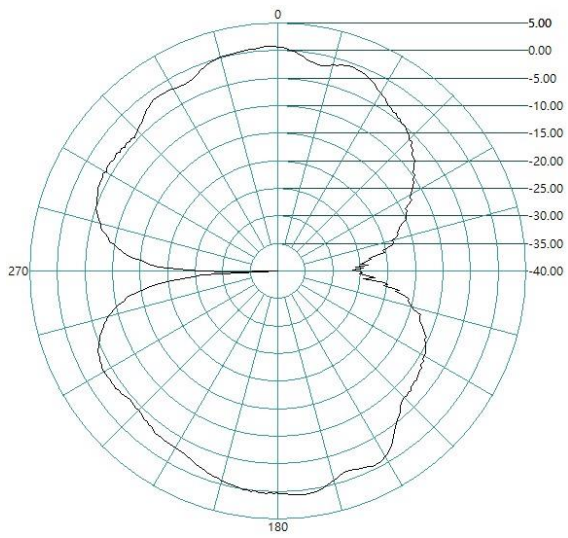

### 2.4GHz

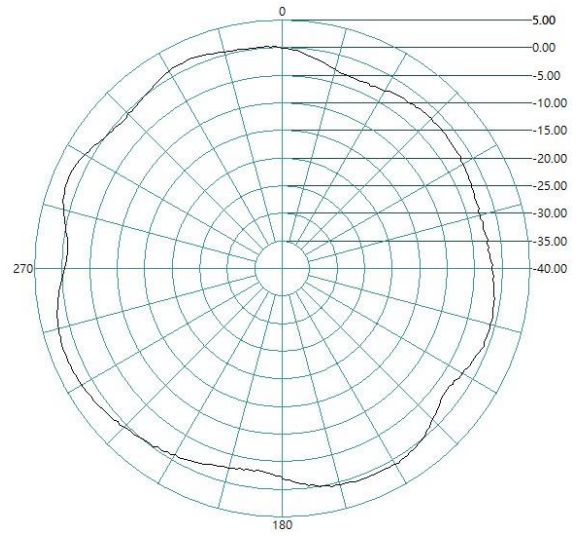
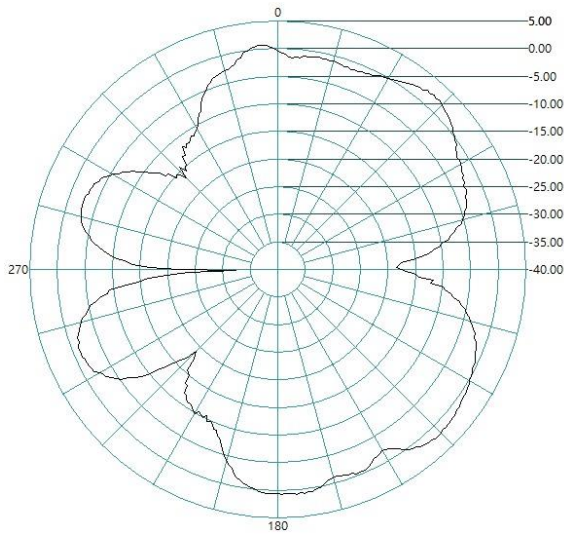

### 2.7GHz

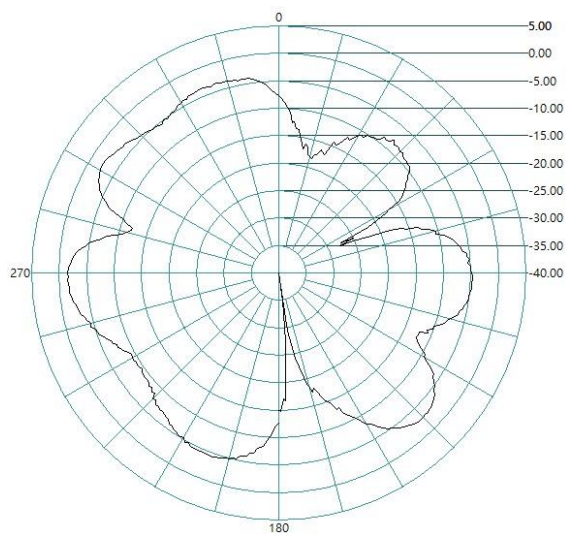
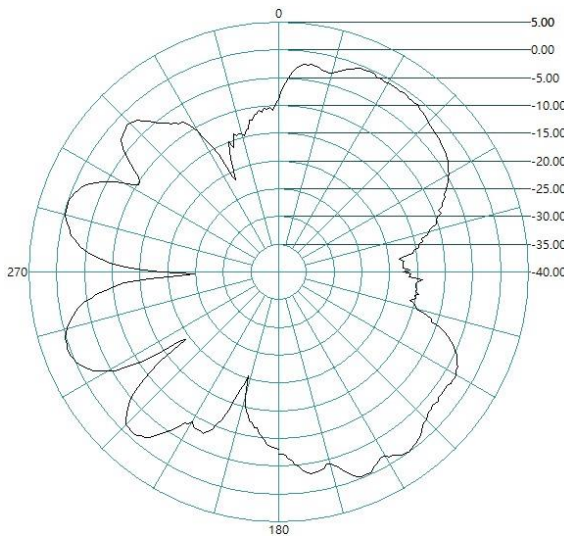

### 3.3GHz

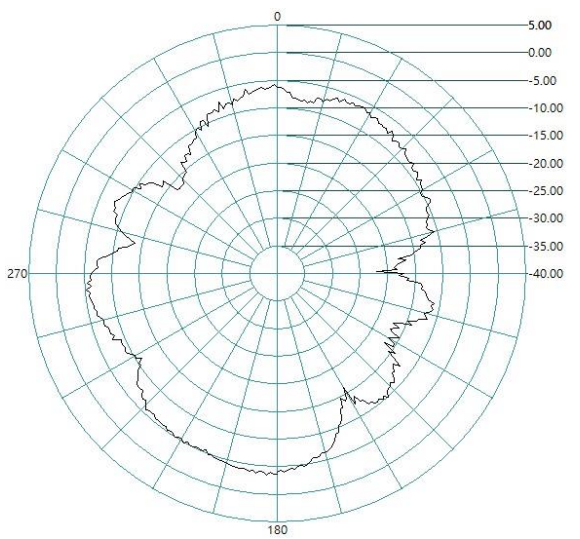
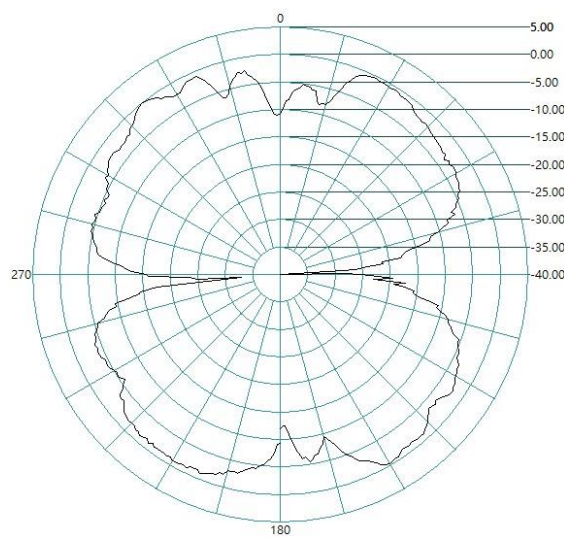



### 3.5GHz

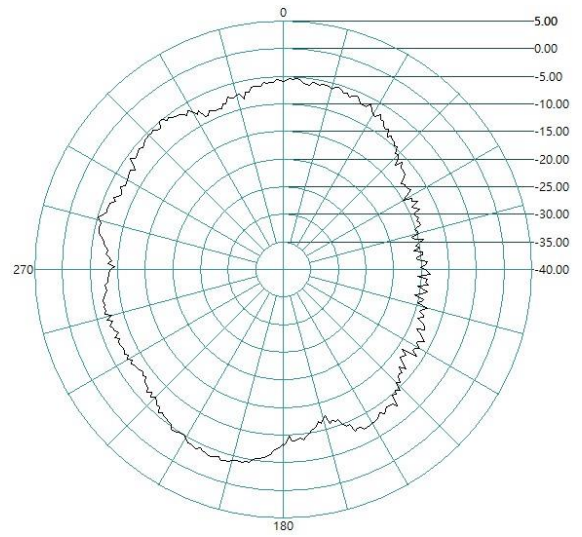
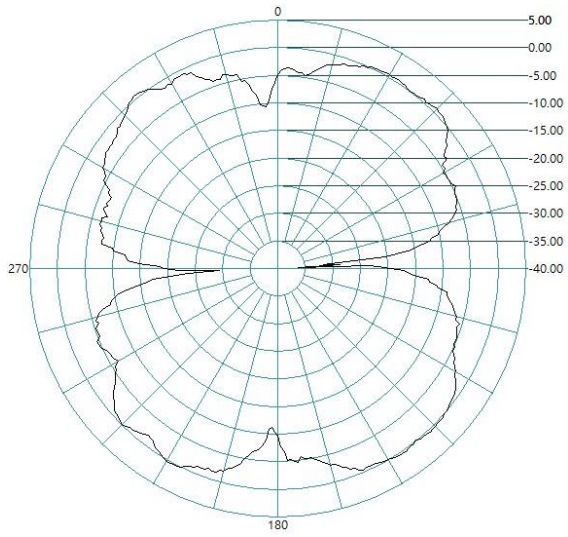

### 3.8GHz

